

# **Frequency Control Concerns In The North American Electric Power System**

**December 2002**

**Prepared by  
B. J. Kirby  
Oak Ridge National Laboratory**

**J. Dyer, C. Martinez  
Electric Power Group**

**Dr. Rahmat A. Shoureshi  
Colorado School of Mines**

**R. Guttromson, J. Dagle  
Pacific Northwest National Laboratory**

## DOCUMENT AVAILABILITY

Reports produced after January 1, 1996, are generally available free via the U.S. Department of Energy (DOE) Information Bridge:

**Web site:** <http://www.osti.gov/bridge>

Reports produced before January 1, 1996, may be purchased by members of the public from the following source:

National Technical Information Service  
5285 Port Royal Road  
Springfield, VA 22161  
**Telephone:** 703-605-6000 (1-800-553-6847)  
**TDD:** 703-487-4639  
**Fax:** 703-605-6900  
**E-mail:** [info@ntis.fedworld.gov](mailto:info@ntis.fedworld.gov)  
**Web site:** <http://www.ntis.gov/support/ordernowabout.htm>

Reports are available to DOE employees, DOE contractors, Energy Technology Data Exchange (ETDE) representatives, and International Nuclear Information System (INIS) representatives from the following source:

Office of Scientific and Technical Information  
P.O. Box 62  
Oak Ridge, TN 37831  
**Telephone:** 865-576-8401  
**Fax:** 865-576-5728  
**E-mail:** [reports@adonis.osti.gov](mailto:reports@adonis.osti.gov)  
**Web site:** <http://www.osti.gov/contact.html>

This report was prepared as an account of work sponsored by an agency of the United States Government. Neither the United States government nor any agency thereof, nor any of their employees, makes any warranty, express or implied, or assumes any legal liability or responsibility for the accuracy, completeness, or usefulness of any information, apparatus, product, or process disclosed, or represents that its use would not infringe privately owned rights. Reference herein to any specific commercial product, process, or service by trade name, trademark, manufacturer, or otherwise, does not necessarily constitute or imply its endorsement, recommendation, or favoring by the United States Government or any agency thereof. The views and opinions of authors expressed herein do not necessarily state or reflect those of the United States Government or any agency thereof.

This report was prepared as a result of work sponsored in part by the California Energy Commission. It does not necessarily represent the views of the Energy Commission, its employees, or the State of California. The Energy Commission, the State of California, its employees, contractors, and subcontractors make no warranty, express or implied, and assume no legal liability for the information in this report; nor does any party represent that the use of this information will not infringe upon privately owned rights.

**Consortium for Electric Reliability Technology Solutions**

**Frequency Control Concerns In  
The North American Electric Power System**

Prepared for the  
Transmission Reliability Program  
Office of Power Technologies  
Assistant Secretary for Energy Efficiency and Renewable Energy

**U. S. Department of Energy**

Principal Authors

Brendan J. Kirby

**Oak Ridge National Laboratory**

Jim Dyer and Carlos Martinez

**Electric Power Group**

Dr. Rahmat A. Shoureshi

**Colorado School of Mines**

Ross Guttromson and Jeff Dagle

**Pacific Northwest National Laboratory**

December 2002

CERTS – Real-time Grid Monitoring and Management

The work described in this report was coordinated by the Consortium for Electric Reliability Technology Solutions on behalf of the California Energy Commission, the Assistant Secretary for Energy Efficiency and Renewable Energy, Office of Power Technologies, Transmission Reliability Program of the U. S. Department of Energy under Contract No. DE-AC03-76SF00098.

Prepared by

Oak Ridge National Laboratory

Oak Ridge, Tennessee 37831-6070

Managed by

UT-BATTELLE, LLC

for the

U. S. Department of Energy

under contract DE-AC05-00OR22725



# Table of Contents

|   |     |
|---|-----|
| FIGURES .....   | iv  |
| ACRONYMS .....  | v   |
| PREFACE .....   | vii |
| <br>  |     |
| 1. INTRODUCTION .....   | 1   |
| 2. A PERSPECTIVE ON FREQUENCY CONTROL .....                                 | 3   |
| 2.1. FREQUENCY REQUIREMENTS UNDER NORMAL CONDITIONS .....                   | 3   |
| 2.2. FREQUENCY RESPONSE UNDER CONTINGENCY CONDITIONS .....                  | 4   |
| 2.3. FREQUENCY CONTROL COORDINATION AND IMPORTANCE .....                    | 5   |
| 2.4. FREQUENCY RESPONSE CAPABILITY: REQUIREMENT VS. MARKET .....            | 8   |
| 2.4.1. Coupling of Frequency Response, Inadvertent Energy and Markets ..... | 8   |
| 2.4.2. Block Schedules and the Impact on Frequency .....                    | 9   |
| 3. FREQUENCY STANDARDS AND CONTROL PERFORMANCE .....                        | 11  |
| 3.1. CONTROL METRICS EVOLUTION .....  | 11  |
| 4. CONCLUSIONS .....  | 17  |
| 4.1. METRICS AND MONITORING SYSTEMS RECOMMENDATIONS .....                   | 17  |



## Figures

|     |   |    |
|-----|---|----|
| 1.  | Power system frequency deviates whenever generation fails to track load precisely.....                                    | 1  |
| 2.  | Generators and transformers have limited volts-per-hertz capabilities.....  | 3  |
| 3.  | Contingency reserves rebalance the system after the sudden loss of generation.....  | 4  |
| 4.  | Frequency is tightly controlled under normal conditions and coordinated under all conditions.....                         | 5  |
| 5.  | Generation is controlled to minimize ACE. ACE contains a frequency bias term to help bring the system back to 60 Hz.....  | 7  |
| 6.  | Average system frequency error rose when A1&2 were replaced with CPS1&2. This is not necessarily bad for reliability..... | 12 |
| 7.  | Frequency and ACE Variations (Start Time is 7:00 AM, May 3, 2002).....  | 13 |
| 8.  | Frequency and ACE Variations (Start Time is 3:00 PM, May 1, 2002).....  | 14 |
| 9.  | Coherence Function Between Frequency Variations and CPS1 and A1 (Control Area 1) .....                                    | 15 |
| 10. | Coherence Function Between Frequency Variations and CPS1 and A1 (Control Area 2) .....                                    | 15 |
| 11. | Coherence Function Between Frequency Variations CPS1 and A1 (Control Area 3) ..   | 16 |
| 12. | Coherence Function Between Frequency Variations and CPS1 and (Control Area 4) .....                                       | 16 |





## **Acronyms**

|       |   |
|-------|---|
| ACE   | area control error                          |
| AGC   | Automatic Generation Control                |
| CPS   | Controlled Performance Standard             |
| ERCOT | Electric Reliability Council of Texas       |
| IEC   | International Electrotechnical Commission   |
| NERC  | North American Electric Reliability Council |
| OCPS  | optimal control performance specification   |
| ORNL  | Oak Ridge National Laboratory               |
| VFD   | variable frequency drive                    |



# Preface

## Purpose

This paper examines the relationship between system frequency, reliability and markets. It was prompted by the frequency deviations recently experienced at 2200 hours daily but is more generally concerned with the question of what frequency control is necessary. The paper does not provide new information or document new research. Nor is it intended to educate readers concerning power system engineering. Instead, the purpose is to reexamine well known truths concerning the power system and to freshly explore the basic relationship between frequency, reliability and markets: stepping back, if you will, to see if we are collectively missing something.

The concern of this paper is with frequency and reliability. Off-nominal frequency can impact reliability and markets efficiency (as we are using the term here) in four ways. It could damage equipment (generation, transmission, or load). It could degrade the quality of the product being delivered to end users (too low and lights would flicker unacceptably, for example). It could result in the collapse of the power system itself (by triggering protective system actions, for example). Or it could result in overloading transmission lines as various generators try to restore system frequency impacting markets efficiency. Often these causes operate in concert. Generator protective systems take action to prevent generator damage, for example, but exacerbate the overall generation/load imbalance.

The paper is divided into two sections. The Introduction is followed by a section titled “A Perspective on Frequency Control” which addresses the physical requirements of the power system and how market transactions interact with the physical system. The “Frequency Standards and Control Performance” section discusses the various NERC and regional reliability council policies that govern utility performance and how these relate to frequency and reliability. Finally, Conclusions are provided.



## 1.0 INTRODUCTION

Electricity is a unique commodity; production and consumption must be matched instantaneously and continuously. A nuclear power plant may have a year of fuel on site. A coal fired power plant can have 90 days of fuel on site. The pipeline fueling a gas fired power plant can have hours of excess fuel packed into the pipe that can mitigate imbalances between the suppliers and consumers. The electric power grid, on the other hand, has only the rotational kinetic energy of the connected synchronous generators to help balance production and consumption: enough energy storage to sustain the grid for cycles to seconds (depending on the amount of imbalance). Too much generation and the system frequency increases, too little and the system frequency decreases. It is not possible to maintain a perfect generation vs. load balance although active control systems attempt to do this by constantly adjusting the generators power input. Figure 1 shows how frequency deviates if generation is slow to respond (left) or if the automatic generation control is imprecise (right). Small mismatches between generation and load result in small frequency deviations. Small shifts in frequency do not degrade reliability or markets efficiency although large shifts can damage equipment, degrade load performance, and interfere with system protection schemes which may ultimately lead to system collapse. Establishing acceptable frequency deviation operational limits is surprisingly difficult. This white paper examines frequency control and frequency deviations in an attempt to help clarify the issues and perhaps move closer to practical and economical performance metrics.

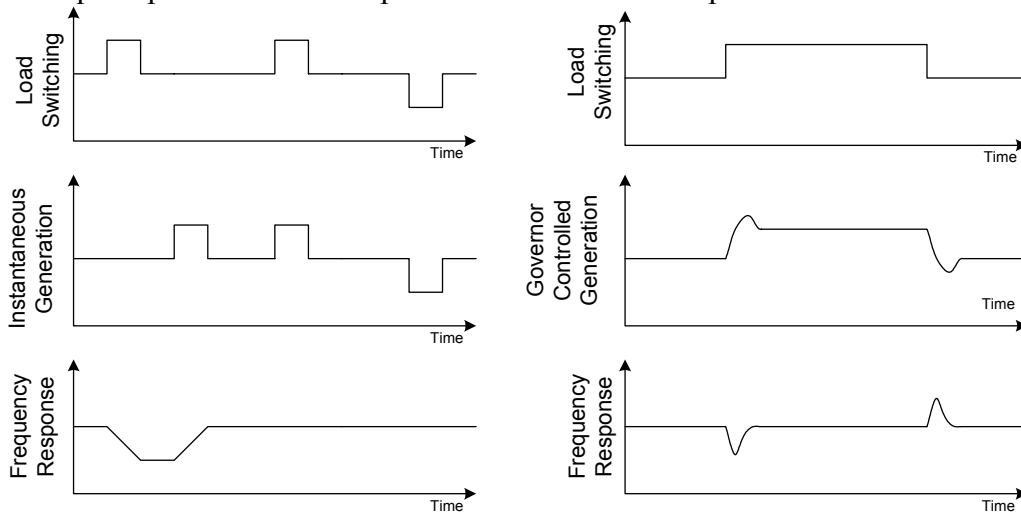

**Figure 1. Power system frequency deviates whenever generation fails to track load precisely.**

The NERC Frequency Excursion Task Force report “22:00 Frequency Excursions” also addresses this problem.<sup>1</sup> Both this report and the NERC report come to similar conclusions providing greater confidence that the situation is being appropriately assessed.

---

<sup>1</sup> NERC Frequency Excursion Task Force, June, “22:00 Frequency Excursions”, North American Electric Reliability Council, Princeton, N.J. 2002



## 2.0 A PERSPECTIVE ON FREQUENCY CONTROL

There are several reasons why the interconnection frequency must be regulated between established limits. Many of these issues are legacy issues which have gradually lost importance as technology advances have increased. Many of the reasons are valid today, and many of them are required due to the way our system has been configured.

### 2.1 FREQUENCY REQUIREMENTS UNDER NORMAL CONDITIONS

Power system requirements often differ for normal and contingency conditions. Tighter tolerances are generally maintained for normal conditions and are relaxed somewhat when contingencies occur.

#### *Power Plant Impacts*

Many existing turbine generators must have frequency regulated to avoid mechanical resonances, but it need not be at the tight control bands of  $\pm 0.05\text{Hz}$  which characterizes normal power system operations in North America. If a rotating machine spins at or near one of its resonant modes mechanical vibration damage can occur. Turbine generator manufacturers design their machine's resonant frequencies to be far away from the intended frequency of operation, so this is not typically a concern unless frequency deviates more than about 5%.

Another issue for power plants is the generators' and transformers' volts-per-hertz limits. Substantial deviation from 60 Hz is not possible without equipment damage. Figure 2, from the International Electrotechnical Commission (IEC) standard IEC 34-1, requires industrial generators to be designed to operate within a minimum ratio between voltage and frequency (called the volts-per-hertz ratio). This ratio defines the flux density in the generator core, which is proportional to the heat losses. Thus a high ratio of volts-per-hertz will cause the generator core laminations to overheat; too high and the unit will eventually fail. This same concept applies equally to transformers.

#### *Load Impacts*

Poor power system frequency control can degrade power quality. Generally, this term refers to much more than frequency control, however, and the power quality impacts of frequency are somewhat vague. Most industrial processes which require a high degree of precision reduce their risk by using variable frequency drives (VFD) to control the motors in plant processes. Most VFDs are insensitive to supply frequency, and their use precisely regulates their output frequency. Therefore systems using VFD are insensitive to small deviations in power system frequency.

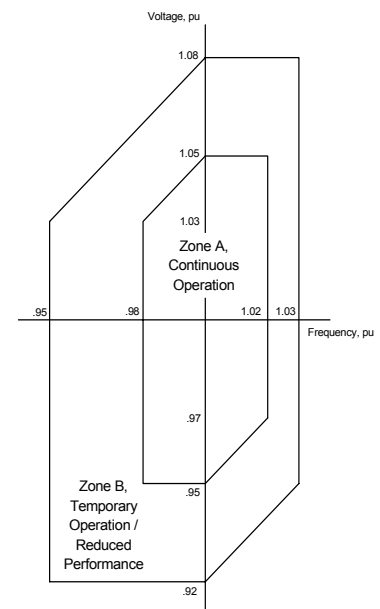

IEC 34-1 Voltage-Frequency Limits for Industrial Generators

**Fig. 2. Generators and transformers have limited volts-per-hertz capabilities**

Electronic equipment rectifies incoming AC power, converting it to DC power before it is used, so the electronic device itself is unaffected by the source frequency. Converters used to rectify the AC source are not frequency sensitive in the range of  $\pm 5\%$ .

### ***Time Correction***

A commonly noted reason for precise frequency regulation is to regulate the time on AC powered clocks. Many of these clocks display time in proportion to the power system frequency. Only relatively long-term (compared with power system transients) average frequency is important, however. For example, a 0.1 Hz frequency deviation that lasted 4 hours would result in an apparent time error of only 24 seconds, an acceptable error for many informal applications if it does not accumulate. Most applications requiring precise time signals no longer rely on the power system for time measurement.

## **2.2 FREQUENCY RESPONSE UNDER CONTINGENCY CONDITIONS**

The sudden loss of a generator or transmission line can instantaneously create a large imbalance between generation and load. The power system is designed to recover from this type of credible imbalance rapidly but frequency can deviate substantially. Figure 3 shows the frequency response for a large loss of generation in a (relatively) small interconnection (ERCOT). Frequency did not drop “too” far and the system recovered within 10 minutes.

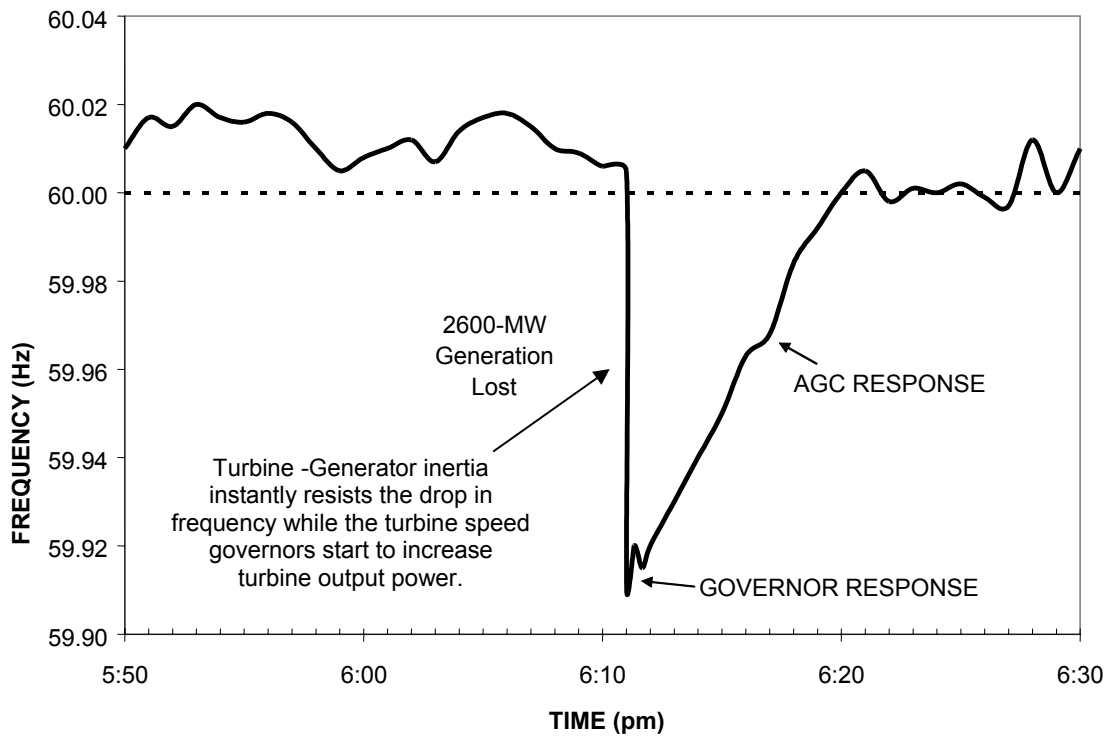

**Fig. 3. Contingency reserves rebalance the system after the sudden loss of generation.**



## 2.3 FREQUENCY CONTROL COORDINATION AND IMPORTANCE

Frequency coordination refers to the nested structure of the frequency control, protection and equipment damage limits. Figure 4 shows this nested coordination. Expansion of any band within Figure 4 will require the re-coordination of all the other protection and control set points within the system. For example, allowing normal frequency variations to move within expanded limits (as is done on some other power systems) will require the re-coordination of Automatic Generation Control (AGC), time correction, governor response set points, generation and load trip set points, and other frequency controlled protection devices. Although this is possible, the engineering and labor to complete this task at a system wide level may be very economically costly.

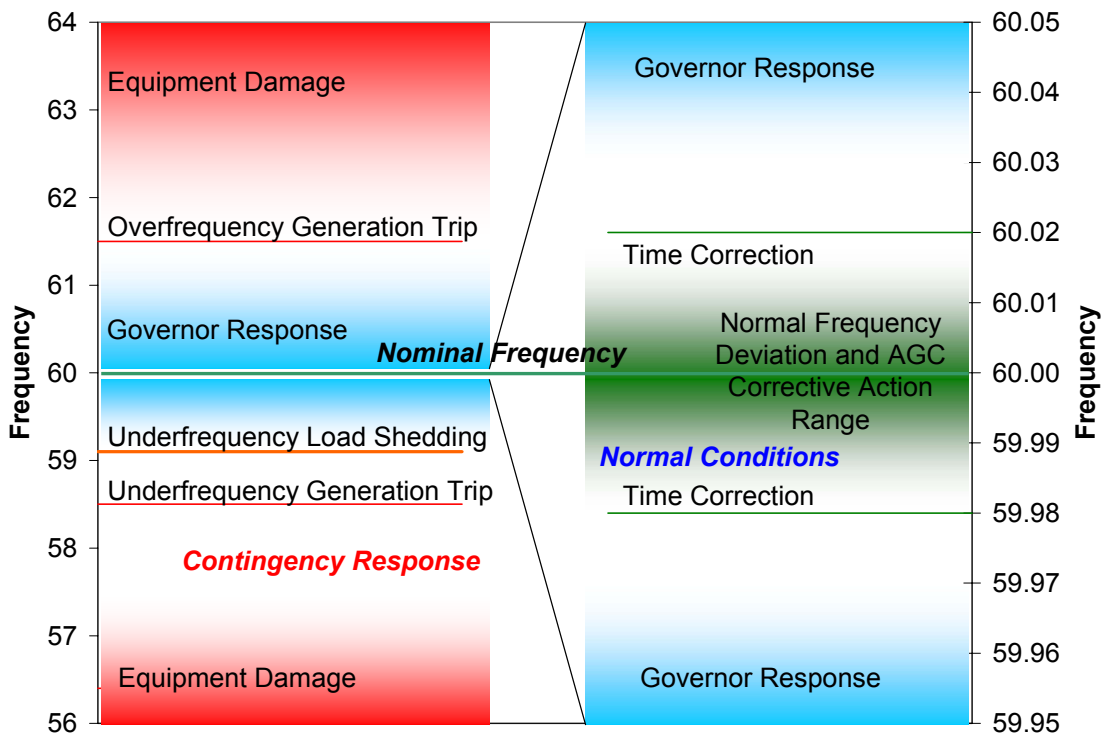

Fig. 4. Frequency is tightly controlled under normal conditions and coordinated under all conditions.

### *Margin for Transient Stability Recovery*

During a transient stability event such as a generation plant tripping off line, the system frequency will drop rapidly due to a mismatch between load and generation, as shown in Figure 3. The level to which frequency falls prior to recovery depends upon its starting point as well as the system inertia. If frequency was initially starting at a high value, then the drop in frequency may not cause any subsequent events. But if the frequency starts from a low value, then the minimum value of frequency just prior to recovery might be below various protective trip set points. Therefore, a tighter range of normal frequency operation will provide a better ability to predict the system response from various system casualties.

The system inertia is the ability of power system to oppose changes in frequency. Physically, it is loosely defined by the mass of all the synchronous rotating generators and motors connected to the system. If system inertia is high, then frequency will fall slowly during a system casualty such as a generator tripping off line. If system inertia is low, then frequency will fall faster during this casualty. Although inertia is not frequency control per se, it does influence the time it takes for a given casualty to cause frequency to fall out of bounds, thus higher system inertia is better than lower system inertia because it will provide more time for governors to respond to the drop in frequency.

### ***Why is Frequency Important?***

Reexamining basic principals can shed some light on frequency response requirements. At the most basic level, the input and output energy of a generator must balance. If more mechanical energy is being delivered to a generator than electrical energy is being removed from the electrical terminals then the excess energy will be stored in the generator's rotation (kinetic energy), resulting in acceleration of the generator. Likewise, if more electrical power is taken out of the generator than mechanical power is put into it, then the generator will decelerate. The magnitude of acceleration depends upon the quantity of the power mismatch, and the inertia of the turbine-generator. Inertia is a physical constant of each turbine-generator that defines its ability to store rotational kinetic energy, and is analogous to mass. Power system frequency responds to a generation and load imbalance in the same manner. The rate at which frequency moves depends upon the magnitude of the energy imbalance and the inertia of all of the generators and loads within the system.

### ***Frequency is tightly controlled under normal conditions and coordinated under all conditions.***

Frequency control has both direct and indirect reliability implications. Figure 4 provided a simplified, conceptual view of power system frequency constraints. Under normal conditions (the right side of the figure) frequency is maintained near 60 Hz by having the power system collectively balance generation and load.

To ensure that each control area carries its fair share of frequency regulation duties, and to ensure that all areas work together in the coordination of frequency, an inter-area system called AGC was developed. An area control error (ACE) signal is computed for each area within the AGC system (Figure 5). This signal dictates the amount of frequency contribution that each area is required to contribute to the entire interconnection.

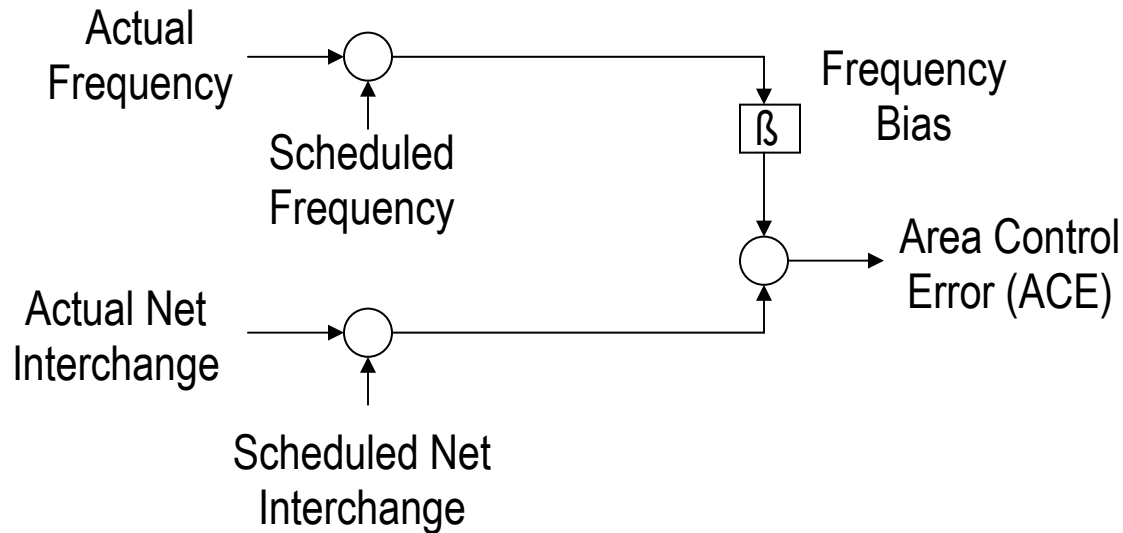

Fig. 5. Generation is controlled to minimize ACE. ACE contains a frequency bias term to help bring the system back to 60 Hz.

A frequency bias term is added to the ACE balancing equation to refine the control. The nominal target frequency is moved up or down by 0.02 Hz periodically to adjust the long-run average frequency. Under normal conditions frequency is controlled very tightly. Reliability is enhanced by ensuring that a few select generators are not the only units providing frequency control to the system. This reinforces the system’s ability to respond to transient stability issues. Furthermore, the ACE signal provides a means to economically balance the maintenance of the entire system, ensuring that the economic burdens of maintaining system frequency falls equally upon all the participating generators.

Reliability is not directly impacted until frequency deviates sufficiently to cause undesired load shedding, generator tripping, damaged equipment or threatens the stability of the system as shown on the left side of Figure 4. Before equipment is damaged a number of control actions occur. Generator governors begin to take autonomous action to restore frequency if it deviates more than 0.036 Hz. The 5% governor droop calls for full output within 3 Hz (5% of 60).<sup>2</sup> This mode of regulation is known as speed-droop regulation.

Not all governors are operated with speed-droop regulation. For example, some hydro generators operate in what is called run-of-the-river mode. This mode of generator regulation opens the throttles (wicket gates of the turbine) to match the water flowing down the river, and is the most efficient use of the renewable water resource. The power generated is decoupled from the system frequency. Thus generators operating in run-of-the-river regulation do not provide speed droop regulation.

A common mode of regulating combustion turbine generators is to have the governor set the throttle position in proportion to the turbine exhaust gas temperature (or sometimes the air inlet temperature). This type of regulation also does not provide any speed-droop regulation for the

<sup>2</sup> In practical application power system frequency does not move 3 Hz and no generator provides its full output range in response to governor action.

power system. Of those, combustion turbine units that do provide speed-droop regulation, many are operated at or near their maximum output capacity, so if a sudden drop in frequency does occur resulting from a system casualty, these generators are not able to respond.

In order for a generator to have the ability to respond to a frequency drop, its governor must be operating on speed-droop control, and it must be operating below its maximum allowable rating. In other words, the ratings of generators and turbines to be purchased and installed must be larger than what is required for the intended application. This can be a hard sell in competitive markets environment.

### ***Frequency as a System Health Indicator***

Frequency provides an indication of the interconnection's generation/load balance. It is instantly available everywhere within the interconnection without the need for additional communications. This facilitates dispersed, autonomous response to system casualties by generators and loads. Assuming that all control systems such as AGC and speed governors are working correctly, a low system frequency is indicative of a low generation reserve.

## **2.4 FREQUENCY RESPONSE CAPABILITY: REQUIREMENT VS. MARKET**

There is a debate going on within the electric power technical community. Should frequency responsive capability be a requirement of all generators or should it be a commercial product (ancillary service)? There is no debate about the need for frequency responsive reserves, both sides agree on the need. Some feel, however, that all generators should be required to have operating governors and to be responsive to system frequency deviations as a condition of being allowed to connect to the grid. Others feel that different generation and load technologies will be in better or worse position (both technically and economically) to provide frequency response and that a market can better determine the best resources to use. Both arguments have merit.

In fact, the two groups are not all that far apart. The "mandatory requirements" group agrees that control areas can voluntarily pool their response if they so desire. The frequency response requirement would then fall on the group rather than the individual control area. If one control area within the group were better able to respond it would be free to do so. That inherently means that there can be a secondary market for frequency response.

### **2.4.1 Coupling of Frequency Response, Inadvertent Energy and Markets**

There is coupling between the reliability requirements of maintaining frequency and the commercial interest in inadvertent energy. Frequency deviates when generation and load are not in balance. The interconnection does not "care" how load and generation are rebalanced as long as it is done quickly and accurately and that transmission constraints are respected. Unfortunately there are very strong commercial interests. So while reliability requires quick action commerce requires accountability. If the rules are not well thought out there can be strong economic incentives for one entity to shift costs to another and create reliability problems markets inefficiency for the power system. It is important for the rapid reliability response to be priced and accounted for, and allocated correctly.

A well functioning imbalance energy market should help restore system frequency. Prices should rise when load exceeds generation providing incentives to loads and generators that are not meeting their schedules to restore the balance. Imbalance markets also provide economic incentives to other resources (both generators and loads) to help restore the generation/load balance if the offending parties are unable to. Frequency excursions are typically brief, however. They may be too brief, and therefore have too little energy content to generate strong enough energy-market signals to motivate rapid response. Even \$1000/MWh only amounts to \$16/MW each minute and only \$0.28/MW each second. Well functioning imbalance markets, which also typically operate on energy transactions, may not be sufficient to maintain reliability.

#### **2.4.2 Block Schedules and the Impact on Frequency**

The objective of restructuring the electric power industry is to increase economic efficiency through competition and free markets. Standardizing the products that are sold in markets makes it easier to compare offerings from different suppliers and can help increase competition. Block scheduling, which defines power transactions as fixed power levels over fixed 4, 8, or 16-hour “blocks”, helps facilitate competitive markets but also makes it more difficult to control the power system and to hold frequency constant.

Block scheduling may facilitate markets but it does not match the physical characteristics of the load or the power system. A 200 MW on-peak block might start at 06:00 and end at 22:00, with a 10 or 20-minute ramp at each end but the load it is being purchased to serve will almost certainly not follow the same pattern. Instead, the load will slowly ramp up in the morning and slowly ramp down in the late evening. The difference between the block schedule and the actual load profile must be accommodated by controlling other generation. Other generation has to ramp down as the scheduled block ramps up at 0600 hours and other generation has to ramp up at 2200 hours when the scheduled block ramps down.

In a study for a major Midwestern utility in 1999 ORNL found that block scheduling of imports and exports accounted for 16% of the regulation burden placed on the generators (minute-to-minute real-power output fluctuations) while accounting for only 11% of the energy.<sup>3</sup> This was especially surprising since most block schedules run for multiple hours and are perfectly flat except for the starting and ending ramps.

Block schedules with 10 or 20-minute ramps could be accommodated when block schedules comprised only a small fraction of the total generation but they create serious problems when that fraction grows. Fortunately there is a relatively simple solution. Extending the ramping time from ten minutes to a full hour would still accommodate standard market design and competition while tying the block schedules much closer to physical needs. The ramp time could also be extended to 30, 40, or 50 minutes and provide progressively greater benefit. Extending the ramp time to an hour accommodates a continuous, multi-hour ramp that the power system typically sees each morning and each evening. The market and the physical system would be better aligned. Nothing would be lost and much would be gained.

---

<sup>3</sup> E. Hirst and B. Kirby 1999, *Does Block Scheduling Waste Money?*, Electrical World, January/February.



## **3.0 FREQUENCY STANDARDS AND CONTROL PERFORMANCE**

### **3.1 CONTROL PERFORMANCE GUIDES**

Current NERC reliability control standards and compliance ownership are in a state of flux, as is the organization of NERC itself. Past “guidelines” are being converted into “mandatory standards” but the process is understandably slow. Standards should be technology and market structure neutral while guidelines, being only examples, need not be.

Some standards address the required outcome: the required generation/load balance and limits on system frequency deviation. Others address the resources required to achieve the desired outcome: the amount and quality of responsive generation and load the system operator must have available to achieve the required generation/load balance and frequency performance. This mix seems appropriate. Power system operators cannot guarantee that they will be able to meet specific balancing, frequency, or reliability standards no matter how hard they try. Similarly, standards that require that specific reliability resources be kept available do not guarantee that those resources will be sufficient to maintain reliability. A combined set of performance and capability standards provide a reasonable balanced approach.

Following are some observations about the industry current control standards:

- Nearly 80% of current operating policies were directed at the Control Area function under old industry organizations. The correct direction at the time, but losing its significance in today's and future operational environments.
- Although a few policies demand compliance by their very nature, (i.e. system protection coordination) all were, and remain, voluntary. New reliability functional models and agreements are trending towards mandatory compliance.
- Tracking and monitoring compliance, where quantification is possible, is inadequate. Today's technologies could offer vast improvements. Quantification is necessary to facilitate mandatory compliance.
- A quarter of century evolution of control-guides and their associated appendixes have over the years resulted in an eclectic structure. Some areas would be better served with clear and succinct guidelines with an associated and detailed reference document provided (i.e. Tagging, Protection, Equipment Requirements)
- Though they are obviously being used to maintain order now, to the extent possible, some of the old NERC policies need to be analyzed and its suitability assessed for the new, evolving operational environments.

### **3.2 CONTROL METRICS EVOLUTION**

A change in frequency regulation standards from A1 and A2 to CPS1 and CPS2 took place in January, 1997. An interesting observation is shown in Figure 6; the Eastern interconnection average frequency error has gotten worse after the implantation of CPS1 and CPS2 standards.

However, this does not necessarily mean that more frequency related problems have occurred. Frequency is still typically controlled well within the “normal” range shown in Figure 4.

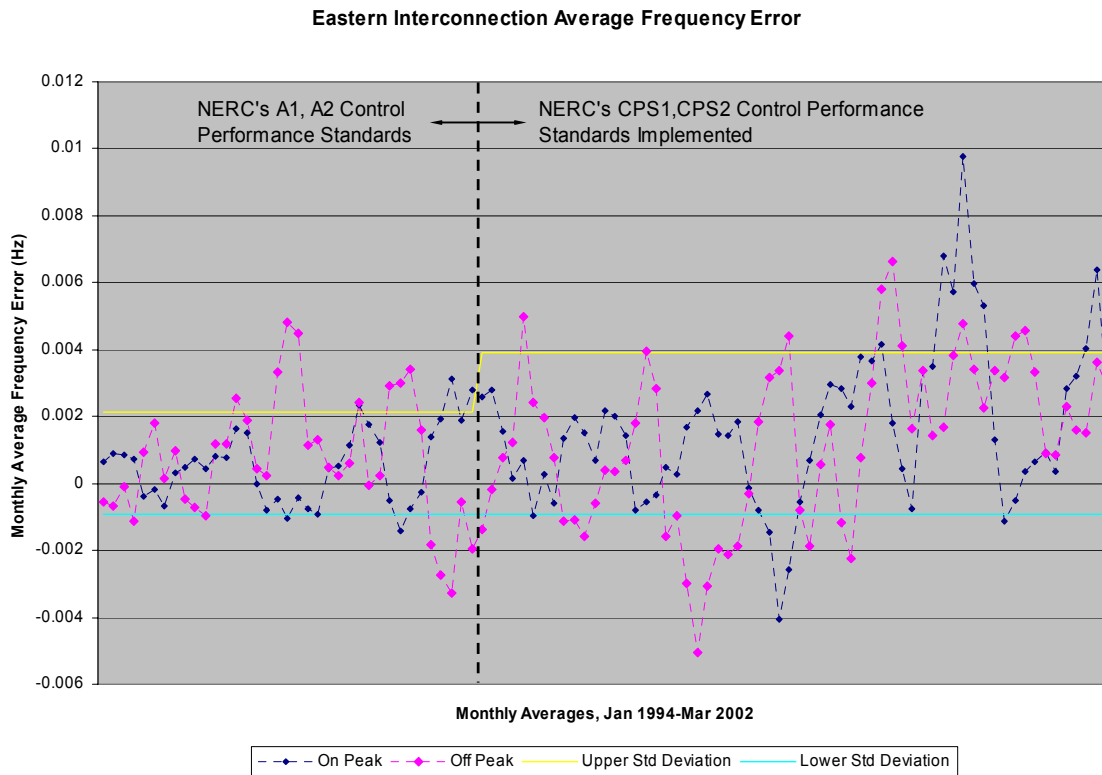

**Fig. 6. Average system frequency error rose when A1&2 were replaced with CPS1&2. This is not necessarily bad for reliability.**

A1 required areas to have a zero ACE crossing every 10 minutes and set maximum upper and lower bounds for the ACE. Typical arguments against these standards are as follows:

1. A1 was an over-controlling standard. If an area's ACE was consistently near zero, yet did not cross zero every 10 minutes, it was found in violation of the standard.
2. The A1 criteria often forced the re-dispatch of generation even if their ACE error was helping to boost system frequency.
3. Control areas could legally and deliberately lean on the grid, operating 99% of their time just above the lower A2 threshold limit, as long as they met A1 by having ACE cross zero once every 10 minutes.

CPS1 and CPS2 are statistical standards that measure overall control area performance yet tolerate occasional lapses. CPS1 also distinguishes between generation/load imbalances which help restore system frequency and those which hurt system frequency restoration.

CPS1 identifies and assigns responsibilities to each control area for variations in the interconnection frequency. The degree of responsibility is related to the size of the control area. Similarly, area control error (ACE) is used as a metric to track compliance within a control area. Thus, noisy ACE is a representative of noisy frequency, which causes problems depicted in Figure 4. The CPS1 equation for a one-minute average can be expressed as



$$\text{CPS1}\% = 100 (2 - \alpha) (\Delta \omega) (\text{ACE})$$

$\Delta \omega$  = frequency variations

ACE = area control error

$\alpha$  = weighting factor

CPS1%=Control Performance Standard 1 Compliance

Therefore, for a perfect condition where every minute the average frequency is exactly on schedule ( $\Delta \omega = 0$ ) or Control Area ACE is zero, then CPS1 is 200%.

We have examined data from several control areas and considered a time window where significant frequency variations were present. Figures 7 and 8 show the frequency data for May 3, 2002 at 7:00 AM and May 1, 2002 at 3:00 PM, representing cases of frequency increases and frequency drops. In order to assess the effectiveness of CPS1 and A1 in tracking these frequency variations, we have performed a coherence analysis between CPS1 and  $\Delta \omega$ , and A1 and  $\Delta \omega$ . Figures 9 through 12 show samples of CPS1 and A1 values for the same time period and their corresponding coherence functions.

Figure 7: Frequency and ACE Variations (Start Time is 7:00 AM, May 3, 2002)

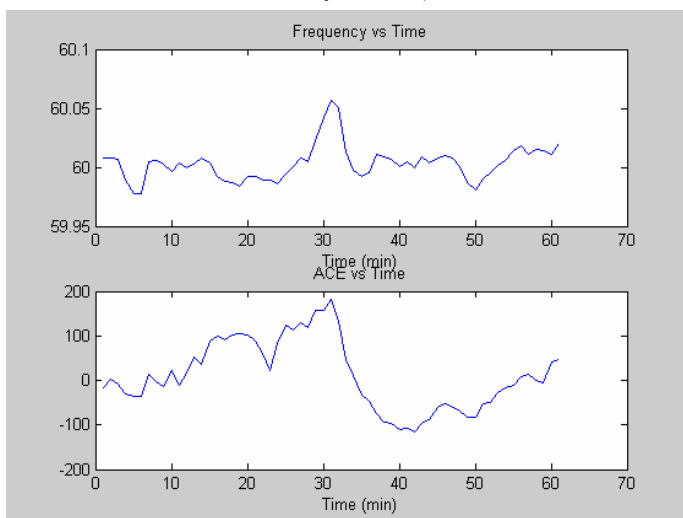

Ideally, if CPS1 or A1 are metrics that track interconnection frequency concerns, then their coherence function should be 1 or close to 1. As can be observed from figures 9 and 10, that is not quite the case. There seem to be inconsistency in the level of tracking. Namely, for the case of frequency increases, CPS1 has high coherence at certain spectral instances, but is very low in most cases. On the other hand, A1 has low coherences in most cases. However, there are instances, as shown in Figure 11, that A1 demonstrates a better correlation to frequency variations than CPS1 does.

Figure 8: Frequency and ACE Variations (Start Time is 3:00 PM, May 1, 2002)

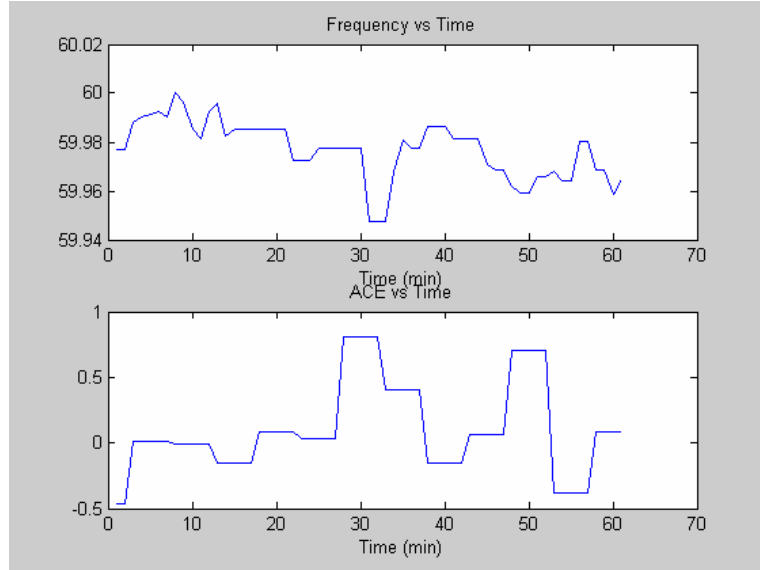

From this preliminary analysis, it is clear that although CPS1 seems to be a definite improvement over A1 in most cases, it is depicted that neither of them can be confidently used for tracking of frequency variations. Furthermore, as described in this paper, tracking of interconnection frequency should be monitored not only for the reliability viewpoint, rather a hybrid of reliability and economics perspective. Therefore, it can be concluded that new metrics need to be devised that better represent this hybrid performance tracking.

From a dynamic programming and optimal control viewpoint, a performance metric could have the following form:

$$OCPS = \int_{t_i}^{t_f} \left[ \alpha_1 (\Delta\omega)^2 + \alpha_2 (ACE)^2 + \alpha_3 (\Delta\omega)(ACE) + \alpha_4 (\rho_{\tau_{i_a}})^2 + \alpha_5 \left(\frac{d\omega}{dt}\right)^2 + \alpha_6 (\Delta\omega)(\rho_{\tau_{i_c}}) + \alpha_7 U^2 \right] dt$$

Where

$\Delta\omega$  = frequency variations

ACE = area control error

$\rho_{\tau_{i_e}}$  = timeline power flow

U= economic indicator

$\alpha_i$  = weighting factor

$t_i$  = initial time

$t_f$  = final time

OCPS= optimal control performance specification

Then by using extensive data from different control areas, we will be able to assess the effectiveness of OCPS, determine best values for  $\alpha_i$ 's, and identify the optimal time window ( $t_f - t_i$ ) where the metric (OCPS) should be averaged over. It should be noted that A1 and CPS1 would be special cases of OCPS, based on values used for  $\alpha_i$ 's.

An analysis using data from different control areas to derive an optimal metric (OCPS) that would have a very high coherence (90% or higher) with  $\Delta \omega$  and ACE, and provides a balance between reliability and economics should be performed.

Figure 9: Coherence Function Between Frequency Variations and CPS1 and A1 (Control Area 1)

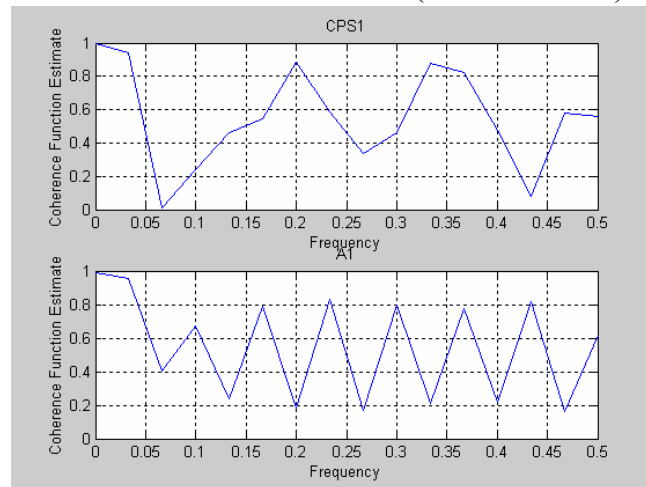

Figure 10: Coherence Function Between Frequency Variations and CPS1 and A1 (Control Area 2)

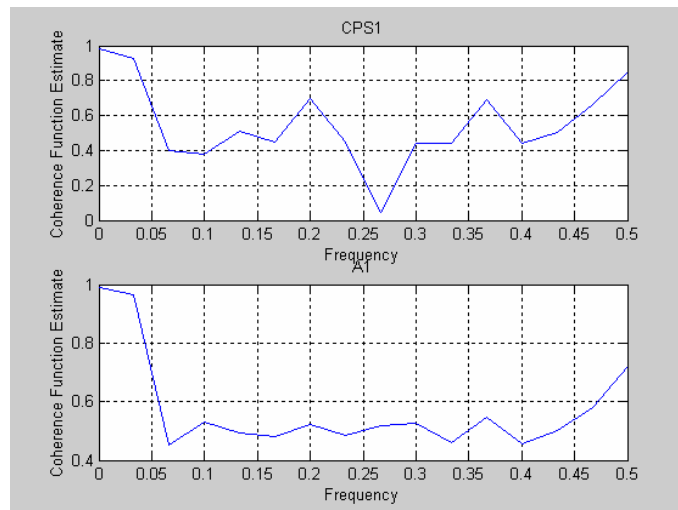

Figure 11: Coherence Function Between Frequency Variations CPS1 and A1 (Control Area 3)

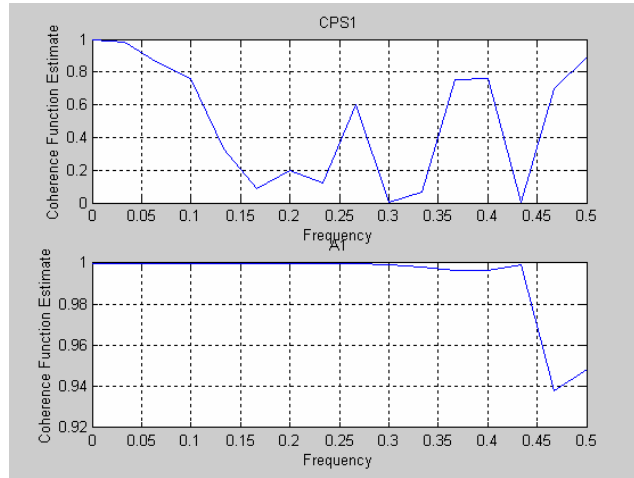
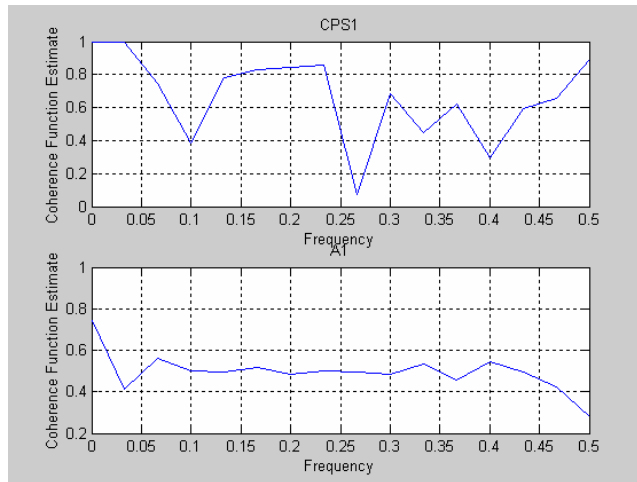

Figure 12: Coherence Function Between Frequency Variations and CPS1 and (Control Area 4)



## 4.0 CONCLUSIONS

This paper examined the relationship between system frequency, reliability and markets. It was prompted by the frequency deviations recently experienced at 2200 hours daily but is more generally concerned with the question of what frequency control is necessary. The preliminary investigation found that frequency is not being controlled as tightly today as it was years ago. Average frequency error doubled (from 0.002 to 0.004 Hz standard deviation) when CPS1 and CPS2 replaced the A1 and A1 performance standards. More recently even higher frequency deviations have been noticed at 2200 hours.

These frequency deviations do not appear to pose an immediate reliability risk. However, a continuous degradation trend will require effective monitoring tools and vigilant operators. The frequency deviations, while measurable, do not move the system drastically closer to equipment damage limits, to load shedding limits or serious markets inefficiencies. Both ours and NERC's analysis does point to the need for further work, however. It was surprisingly difficult to determine which control areas were responsible for the 2200 hour frequency deviations, for example. It is also surprisingly difficult to state what frequency deviations are unacceptable. Work is required to:

- Improve the real-time observability of the power system and supply security coordinators with tools to determine when frequency excursions are occurring and which control areas are responsible.
- Research and establish more effective metrics for acceptable frequency performance.

Daily block schedules appear to contribute to the degraded frequency performance of power system. There also appears to be little reason for daily block schedules with 10 or 20-minute ramps. The loads the block schedules are serving are not ramping that fast. Generation resources are required to counter the fast block ramps, wasting rapping capacity. The generators providing the block schedules gain little from the fast ramping requirements either. A great deal would be gained and little would be lost if the ramps associated with 16 hour long blocks were extend to a full hour.

### 4.1 METRICS AND MONITORING SYSTEMS RECOMMENDATIONS

The first year effort on this project provided a comparative assessment of different metrics used to evaluate reliability and performance. This analysis has demonstrated potential cause and effect relationships between load variations and change of signature delineated by different metrics. Therefore, the project team, supported by the NERC task force recommendation for further study and tool development, proposes a more comprehensive study, using extensive data, to enable derivation of conclusive results that would lead to the following deliverables:

- Tracking metrics that comprise of appropriate balance between performance and economics
- Determination of other system characteristics and measurable parameters that are more representative of the contemporary electric market

- Real-time monitoring systems for enhanced grid tracking metrics

In order to achieve the goals of this study, it is proposed to carry out the following key tasks:

- Identifying control areas with pronounced and concerning signatures and load profiles
- Assessment of different periods within a year with highest correlation to concerning signatures
- Assessment of such transient periods as ramping generation and introduction of significant highly varying loads
- Determination of representative time periods and system measurands, e.g.  $\Delta\omega$ , that identify performance or market concerns
- Development of correlation functions between system measurands and present control performance specifications, e.g., CPSI, CPS2, A1, A2 and other future proposed standards.
- Sensitivity analysis based on weighting functions of economic and performance that result in an optimum formulation of monitoring metrics
- Validation of the metrics based on data from different control areas, transient times, and season

Results of this study will provide scientifically-based metrics that accurately represent performance and economic impact at both micro and macro scales of the grid, and will help to respond to fundamental stakeholders and policymakers questions such as: is grid reliability being degraded, are markets efficient and are transmission systems fully utilized.

INTERNAL DISTRIBUTION

1. M. R. Ally, 3147, MS-6070
2. M. A. Brown, 4500N, MS-6186
3. P. D. Fairchild, 3147, MS-6070
4. M. A. Karnitz, 4500N, 6186
- 5-9. B. J. Kirby, 3147, MS-6070
10. ORNL Central Research Library, 4500N, MS-6191
- 11-12. Laboratory Records, 4500N, MS-6285

EXTERNAL DISTRIBUTION

13. Fernando L. Alvarado, Professor, Department of Electrical and Computer Engineering, University of Wisconsin-Madison, 2544 Engineering Hall, 1415 Engineering Drive, Madison, WI 53706, E-mail: [Alvarado@engr.wisc.edu](mailto:Alvarado@engr.wisc.edu)
14. Vikram S. Budhraj, President, Electric Power Group, LLC, 201 South Lake Avenue, Suite 400, Pasadena, CA 91101, E-mail: [budhraj@electricpowergroup.com](mailto:budhraj@electricpowergroup.com)
15. Jeff Dagle, Pacific Northwest National Laboratory, 2400 Stevens Drive, K5-20, Richland, WA 99352, E-mail: [jeff.dagle@pnl.gov](mailto:jeff.dagle@pnl.gov)
16. Jim Dyer, Electric Power Group, LLC, 201 South Lake Avenue, Suite 400, Pasadena, CA 91101, E-mail: [dyer@electricpowergroup.com](mailto:dyer@electricpowergroup.com)
- 17-21. Joseph Eto, CERTS Program Manager, Lawrence Berkeley National Laboratory, Bldg. 90 Room 4126K, MS: 90-4000, University of California, Berkeley, CA 94720
22. Charles Goldman, Environmental Energy Technology, Lawrence Berkeley National Laboratory, 1 Cyclotron Road, MS: 90R4000, Berkeley, CA 94720, E-mail: [CAGoldman@lbl.gov](mailto:CAGoldman@lbl.gov)
23. George Gross, Professor, Department of Electrical and Computer Engineering, University of Illinois at Urbana-Champaign, 339 William L. Everitt Laboratory, MC 702, 1406 West Green Street, Urbana, IL 61801, E-mail: [gross@staff.uiuc.edu](mailto:gross@staff.uiuc.edu)
24. Ross Guttromson, Pacific Northwest National Laboratory, 2400 Stevens Drive, Richland, WA 99352, E-mail: [Ross.Guttromson@pnl.gov](mailto:Ross.Guttromson@pnl.gov)
25. Carl H. Imhoff, Product Line Manager for Energy Operations and Maintenance, Pacific Northwest National Laboratory, 902 Battelle Boulevard, P. O. Box 999, Richland, WA 99352, E-mail: [Carl.Imhoff@pnl.gov](mailto:Carl.Imhoff@pnl.gov)
26. Mark D. Levine, Director, Environmental Energy Technologies Division, Lawrence Berkeley National Laboratory, 1 Cyclotron Road, MS-90R3027D, Berkeley, CA 94720, E-mail: [mdlevine@lbl.gov](mailto:mdlevine@lbl.gov)
27. Chris Marnay, Energy Analysis, Lawrence Berkeley National Laboratory, 1 Cyclotron Road, MS 90R4000, Berkeley, CA 94720, E-mail: [C\\_Marnay@lbl.gov](mailto:C_Marnay@lbl.gov)
28. Carlos A. Martinez, Electric Power Group, LLC, 201 South Lake Avenue, Suite 400, Pasadena, CA 91101, E-mail: [martinca@edisonX.com](mailto:martinca@edisonX.com)

29. Timothy D. Mount, Professor, Applied Economics and Management, 214 Warren Hall, Cornell University, Ithaca, NY 14853-7801, E-mail: [tdm2@cornell.edu](mailto:tdm2@cornell.edu)
30. Shmuel S. Oren, Department of Industrial Engineering and Operations Research, 4119 Etcheverry Hall, University of California at Berkeley, Berkeley, CA 94720-1777, E-mail: [shmuel@euler.berkeley.edu](mailto:shmuel@euler.berkeley.edu)
31. Philip N. Overholt, EE-16/Forrestal Building, U. S. Department of Energy, 1000 Independence Avenue, SW, Washington, DC 20585
32. Alonso Rodriguez, Electric Power Group, LLC, 201 South Lake Avenue, Suite 400, Pasadena, CA 91101
33. William D. Schulze, Professor, Applied Economics and Management, 301 Warren Hall, Cornell University, Ithaca, NY 14853-7801, E-mail: [wds3@cornell.edu](mailto:wds3@cornell.edu)
34. Richard E. Schuler, Professor, Civil and Environmental Engineering and Economics, 466 Uris Hall, Cornell University, Ithaca, NY 14853-7801, E-mail: [res1@cornell.edu](mailto:res1@cornell.edu)
35. Rahmat A. Shoureshi, Colorado School of Mines, ACEPS Center, Brown Building, Room 330, Golden, CO 80401-1888, E-mail: [rshoures@slate.mines.edu](mailto:rshoures@slate.mines.edu)
36. Sarosh N. Talukdar, Carnegie Mellon, ECE Department, Pittsburgh, PA 15213, E-mail: [talukdar@ece.cmu.edu](mailto:talukdar@ece.cmu.edu)
37. Marjorie Tatro, Director, Energy and Transportation Security Department, Sandia National Laboratory, 1515 Eubank SE, MS 0704, Albuquerque, NM 87185-0704, E-mail: [mltatro@sandia.gov](mailto:mltatro@sandia.gov)
38. Robert J. Thomas, Director, Power Systems Engineering Research Center, Cornell University, 428 Phillips Hall, Ithaca, NY 14853, E-mail: [rjt1@cornell.edu](mailto:rjt1@cornell.edu)