

Exhibit Number	:	
Proceeding Number	:	R.99-10-025
Commissioner	:	R. A. Bilas
Admin. Law Judge	:	M. Cooke
Witness	:	T. Key, B. Kirby

ORA

**Office of Ratepayer Advocates
California Public Utilities Commission
State of California**

**ORA's Report on Phase I and Related Issues
In the Order Instituting Rulemaking
Into Distributed Generation**

Chapter 7

**Technical Evaluation of Operational and Ownership
Issues of Distributed Generation in California**

**Pacific Gas and Electric Company
Southern California Electric Company
San Diego Gas & Electric Company**

Rulemaking R.99-10-025

***San Francisco, California
April 12, 2000***

Chapter 7

Technical Evaluation of Operational and Ownership Issues of Distributed Generation in California

Prepared for:

Office of Ratepayer Advocates
California Public Utility Commission

Prepared by:

Thomas S. Key
EPRI PEAC Corporation
Knoxville, TN

Brendan J. Kirby
Consultant
Knoxville, TN

Table of Contents

7.A	Summary and Key Findings (witness B. Kirby)	1
7.A.1	Summary	1
7.A.2	Key Findings	1
7.B	Background (witness T. Key)	3
7.B.1	Brief History of Electric Power System	3
7.B.2	Distributed Generation in California	5
7.B.3	Emerging Interconnection Practices	7
7.C	Electrical Power System Fundamentals (witness T. Key)	10
7.C.1	Electric Power System Overview	10
a)	Transmission Level	14
b)	Bulk-Substation Level	15
c)	Sub-Transmission Level	16
d)	Distribution-Substation Level	16
e)	Feeder Level	17
f)	Lateral Feeds	19
7.C.2	Attributes of Traditional Vertically Integrated Utility System	19
7.C.3	Electric Power System Future Structure	21
7.C.4	End-Use Consumption Component	23
a)	Key Elements that Compose End-Use Consumption	23
b)	Functions of End-use Consumption	24
c)	Types of End-use Consumption	24
7.C.5	The Generation Component	25
a)	Key Elements that Compose Generation	26
b)	Functions of Generation	28
c)	Types of Electric Generators	29
d)	Auxiliary Losses within the Generation	33
7.C.6	Transmission and Distribution Component	33
a)	T&D Reliability Benefit	34
b)	T&D Load Diversity Benefit	35
c)	T&D Economic Benefit	35
d)	Key Elements that Comprise T&D	36
e)	T&D Jurisdiction	37
f)	Functions of Transmission and Distribution	37
g)	Types of Transmission and Distribution	38
7.C.7	Established Policy Objectives and DG	44
a)	Adequate Safety with Deregulation	45
b)	High Reliability	49
c)	Reliability Indices	49
d)	Reliability Index Survey	50
e)	Reliability Events	51
f)	Reliability and T&D with DG	51

g)	Reliability Enhanced at End-User with DG.....	52
h)	Reliability Concerns for Distribution Feeder with DG.....	53
i)	Reliability and T&D with End-Use Consumption.....	55
j)	High Quality Power	55
k)	Quality Power and T&D with DG	57
l)	Quality Power and T&D with End-Use Consumption	60
m)	Minimal Environmental Impact.....	60
n)	Emission Control Technologies.....	61
o)	Environment and T&D with DG.....	63
p)	Environment and T&D with End-Use Consumption.....	64
q)	Reasonable Cost.....	65
r)	Economy and T&D with DG	65
s)	Economy and T&D with End-use Consumption	66
t)	Clarification of Loop Flows.....	66
7.D	Analysis of Distributed Generation Impacts On Distribution (witness B. Kirby).....	67
7.D.1	Overview.....	67
a)	T&D Reliability Benefit	68
b)	T&D Economic Benefit	68
c)	T&D Load Diversity Benefit	69
d)	T&D and Generation.....	69
7.D.2	Technical Attributes of End-use Consumption.....	70
a)	Voltage Level.....	70
b)	Peak Demand	70
c)	Energy Consumption	70
d)	Regulation Requirement	70
e)	Impedance	71
f)	Energizing and Inrush Current.....	71
g)	Diversity and Duty Cycle.....	71
h)	Power Factor	71
i)	Dynamic Response.....	71
j)	Current Distortion	72
7.D.3	End-use Consumption and DG	72
a)	Real-Time Energy Consumption or Production	72
b)	Individual Ancillary Service Consumption or Production.....	72
c)	Location.	73
7.D.4	Technical Attributes of Generation.....	73
a)	Voltage Level.....	74
b)	Power Capacity	74
c)	Energy Capacity.....	74
d)	Efficiency	74
e)	Short-Circuit (SC) kVA	74
f)	Ramp Rate.....	74
g)	Dispatchability	75
h)	Reliability.....	75
i)	Reactive Power and Voltage Support	75
j)	Voltage Quality.....	75

k)	Current Quality	75
l)	Comparison of Central Plant and Distributed Generation Attributes	75
7.D.5	Disaggregate California Generation	77
7.D.6	Ancillary Services within the T&D	79
a)	System Control.....	80
b)	Regulation.....	81
c)	Operating Reserve.....	82
d)	Spinning Operating Reserve	82
e)	Non-Spinning Operating Reserve	83
f)	Replacement Reserve.....	83
g)	Voltage Control and Black Start	84
7.D.7	Technical Attributes of T&D	85
a)	Voltage Level.....	85
b)	Power Transfer Limits	85
c)	Line Loss.....	86
d)	Short-Circuit (SC) kVA at PCC.....	86
e)	Reactive Power Requirements	86
f)	Voltage Regulation and Drop	87
g)	Overload and Short-Circuit Protection	87
h)	Lightning Protection and BIL	87
i)	Grounding	88
7.D.8	Key Operations and Assets in a Restructured EPS	88
7.D.9	Congestion Constraints in a Restructured EPS	89
a)	Definition of <i>Congestion</i>	90
b)	Description of Transmission Congestion.....	92
c)	Application of “Congestion” Definition to the Case of Distribution.....	94
d)	Impact of Adding T&D versus DG Capacity on DG Dispatch	98
e)	Technical Feasibility of DG Providing Ancillary Services	101
7.D.10	Ancillary Services in a Restructured EPS.....	103
Glossary		105
Appendix 7.A Distributed Generation versus Load.....		115
Qualifications and Prepared Testimony of Thomas Key		117
Qualifications and Prepared Testimony of Brendan Kirby.....		119

7.A Summary and Key Findings (witness B. Kirby)

7.A.1 Summary

Before California fully opens the door to distributed power resources, some fundamental questions regarding technical feasibility of functional unbundling at the distribution level need to be carefully evaluated. If unbundling at the distribution level is technically and economically feasible, then distributed generation (DG) can be owned and operated independently of the regulated transmission and distribution (T&D) system. The objective for the restructured electric industry is to provide energy services that are safe, reliable, of high quality, with minimal environmental impact, and at reasonable prices.

Unbundling of distributed generation from distribution may ultimately lead to a much less centralized and significantly different power system. It is not obvious exactly how all policy objectives for the electric services industry will be affected. Models for the unbundled system need to be described and compared to the traditional vertically integrated power system with regard to design and performance in meeting the established policy objectives.

In this report, an assessment is made on how unbundling of distributed generation in California is likely to affect policy objectives set in California for the restructured electric services industry. Starting with fundamental concepts of the electric power system and defining specific functions will help to facilitate a comparison of centralized and decentralized approaches. This chapter identifies the specific functions and the minimum set of technical attributes for the generation, transmission, distribution, and end-use load components of the power system. Also identified are the appropriate attributes that effectively classify T&D into two or more sub-functions, distinguish them from other functions, and distinguish central from distributed generation. Ancillary energy services at the distribution level are described (there may be “ancillary” services within T&D that are not “energy” activities).

7.A.2 Key Findings

The electric power system (EPS) is composed of three distinct parts:

- Load: The beneficial use of electric energy.

- Generation: The production of electric energy to serve loads.
- Transmission and Distribution: The transport of electric energy between loads and generation.

There is no clear break separating transmission from distribution. Both systems work together as part of the same larger system that interconnects loads and generators. There are practical characteristics that are useful for distinguishing the two (distribution systems tend to be at lower voltage levels, be radial rather than networked, and move power in only one direction), but these characteristics are not absolute.

Similarly, there is no clear break separating distributed generation from central generation. There are practical characteristics that are useful for distinguishing the two (distributed generators tend to be distributed among the loads, are smaller in size, and are more amenable to co-generation), but again, these characteristics are not absolute.

Providing distributed generators (and loads) access to real-time energy and ancillary service markets helps them by giving them another source of income, helps the overall power system by increasing the supply of reliability services, and helps all customers by reducing the cost of reliability through increased market participation on the supply side.

Congestion can often be relieved either through modifying the existing generation dispatch, enhancing the transmission or distribution system, or causing installation and operation of new local generation.

Adequacy of a transmission and distribution system has two criteria: 1) The system must have enough capacity to support the balancing of load and generation, even during known and expected outages. 2) It must have enough capacity so that competitive generation markets can function. When there is a desire or need to move more power through a portion of the transmission and distribution system than the system can support, congestion results. Congestion can be addressed through transmission or distribution investment, generation investment (either market- or regulation-based), market-based modifications to generation and/or load operations, or, in the absence of a better solution, compelled modifications to generation and/or load operations. The interactions between regulated transmission and

distribution investment, operations and market-based generation investment, and operations require careful attention.

Fundamentally, congestion is the same on the transmission system as it is on the distribution system. In both cases, congestion results when there is a desire to move more power through an element of the system than that element can accommodate. To the extent that distribution systems are often radial while transmission systems are often networked, there can be differences in how congestion is managed.

Technically, there is no reason why decentralized generation cannot be seamlessly integrated with the distribution system without affecting reliability. There is a limit to the amount of DG that can be installed and operated on a distribution feeder. The limit depends on the limits of the existing protection scheme, allowed power flows, and the capacity of the basic distribution equipment. Congestion, which causes denial of access¹, results when that limit is reached.

Based on these key findings, unbundling at the distribution level is technically and economically feasible and can meet the established policy objectives set for the restructured electric services industry in California to provide energy services that are safe, reliable, of high quality, with minimal environmental impact, and at reasonable prices. Distributed generation can be owned and operated independently of the regulated transmission and distribution system. T&D facilities can be owned and maintained by parties other than the system operator. However, the system operator must not have commercial interest in the energy markets. If the system operator had a commercial interest in energy markets, then the controlling authority in favor of that interest might be exercised.

7.B Background (witness T. Key)

7.B.1 Brief History of Electric Power System

A century ago, electricity was a competitive industry, similar to many other industries. Economies of scale and scope rapidly lead the way for vertical integration and franchised monopolies to become the successful industry model, similar to the evolution of other utility industries such as telephone communications. After decades of ever-increasing efficiency

¹ Access includes physical connection and unconstrained freedom to operate.

coming from ever-larger central generators that were owned and operated by regulated monopolies, the industry began to experience change during the later part of the 20th century. Large central power plants became increasingly difficult to site and to build. In the future, power plants are expected to be smaller, more dispersed through the electric power system, and may be owned by anyone.

Legislation leading to deregulation has also changed the structure of the electric industry. Distributed generation was considered early in the history of deregulation. The Public Utilities Regulatory Policy Act (PURPA) of 1978 enabled independent generators to sell electricity to regulated utilities. The Energy Policy Act of 1992, and Federal Energy Regulator Commission (FERC) Order 888 issued in 1996, opened the wholesale electricity markets to competition. FERC's Order 2000 dealing with Regional Transmission Organization (RTO) and issued in December of 1999 reaffirms FERC's commitment to restructuring the electric utility industry throughout the U.S. In California, the key legislative action was AB1890, enacted in 1996. The legislation was pursuant to a series of studies, reports, investigations, and findings of the California PUC, combined with the input of numerous stakeholders.

Today, with the introduction of commercially available and more cost-competitive small generators, three independent forces are driving increased interest:

1. The electric power industry is restructuring and will become one in which competitive generation markets and suppliers compete for customers—not one based on vertically integrated regulated monopolies with franchise service territories and captive customers.
2. Natural gas is the fuel of choice when considering new generation. Twenty years ago, it was illegal to burn gas to produce electricity. Now gas is plentiful and competitively priced, and it is encumbered with far fewer pollution concerns than most other fuels.
3. New technologies are potentially going to make small-scale generation cost-competitive with large central stations. Combustion turbines in the 10- to 100-megawatt range have been transformed from expensive peaking units to base-load-capable generators with efficiencies above 55 percent when operated as combined cycle plants. More recently, microturbines in the tens-of-kilowatts range are coming to market. Their manufacturers claim that production costs will soon be very competitive with delivered retail power

prices. Internal combustion engines are also benefiting from evolving technology. In the longer term, fuel cells, photovoltaics, wind, and Sterling engines are expected to be commercial viable. Generation co-located with heat-consuming processes also makes cogeneration—or combined cooling, heat, and power (CCHP)—possible on a much wider scale. Higher fuel efficiencies in these systems improve the economics of smaller generators and may accelerate deployment of distributed generators.

Combined, these three forces accelerate the drive for acceptance of new generation technologies and a new industry structure. Competitive markets favor technologies that are low in capital cost, quick to deploy, and modular, so that they can respond rapidly to changing market conditions. Major new generation projects that take 15 years or more to plan, site, design, and build (those based on coal or uranium, for example) are essentially impossible under today's market conditions. Forward-thinking utilities in California have recognized these trends and are beginning to look at smaller generators dispersed in their sub-transmission and distribution systems. It is likely that from these efforts the new term “distributed generation” was coined to describe utility-owned generation at the distribution level in the power system.

Since the restructuring of the utility industry, the term has come to mean small generators dispersed in the electric power system at any level and owned by anyone. This concept is further promoted by abundant supplies of natural gas, a ready fuel for smaller and easier-to-deploy generation technologies. Development of smaller and more efficient gas-burning technologies is encouraged by gas suppliers eager to find new markets for their product. End users are responding to deregulation and want to look at their options to meet their growing electricity needs, including onsite generation. The outcome of all of this is expected to be a more decentralized power system and the growing use of distributed generation (DG).

7.B.2 Distributed Generation in California

Restructuring of the utility industry in California has opened a new energy market, allowing many end users to choose an energy provider, method of delivery, and attendant services. This market is expected to expand the use of small, modular power technologies that can be installed quickly and have the potential for efficient energy conversion and reduced environmental concerns. At the same time, many technology advancements favor smaller

generators. Also, renewable sources of energy and natural gas provide environment advantages. Given these factors, it is clear that distributed electric generation and storage will be seriously considered in California.

California is one of 12 states that have enacted restructuring legislation. The state has undertaken the role of ensuring fair competitive access to the transmission and distribution grid for independent power producers. At the transmission level, California already has an independent system operator (ISO). The state regulates local electrical distribution systems and ensures their reliable operation. However, no formal action has been taken to encourage third-party-owned generation at the distribution level. Incentives for new distributed generation at the distribution level are not planned, and the California Public Utilities Commission (CPUC or Commission) intends to let the free market determine the value of these systems.

At the same time, operators of electric systems have expressed concerns about economic dispatch, coordination of protection, power system control, and availability of energy. These operational issues and related electric system design practices need to be evaluated. Adding significant amounts of third-party or customer-owned generation at the distribution level may not fit traditional notions of how power systems work. Existing system configurations and operating practices are likely to present penetration limits. Even so, a review of the first principles of power system operation and control functions are not likely to rule out high penetrations of generation at the distribution level.

At the consumer level, California continues to promote new generation from renewable energy resources. The 1998 Assembly Bill No 1755 updated the State Public Utility Code, which allowed “net metering” for wind and solar electric systems rated at 10 kW or less. The California Energy Commission (CEC) is currently developing a screening process to identify distributed generators that require minimal review and studies by utility distribution companies (UDCs) and minimal additional interconnection requirements.

Small increments of generation near load centers provide different challenges and advantages when compared to large increments of generation at a distance. Practices established for the traditional vertically integrated power system will likely need to be modified for future unbundled power systems containing distributed generation. For

example, new dispatch, voltage-control, protection, and relaying practices may be able to exploit the benefits of DG rather than be a barrier to it. In a similar way, the establishment of standard interconnection practices can reduce the cost of bringing small generators on line. Planning methods for new distribution have already been proposed. These methods give appropriate consideration to options for distributed generation. The expansion of the ancillary-services market to include distribution and DG will encourage free-market innovation toward supplying them.

7.B.3 Emerging Interconnection Practices

In the past, energy providers have negotiated interconnections for non-utility generation (NUG) according to the requirements of the power company and the specific installation, including technical interface and commercial arrangements. Typically, the machines used in distributed or co-generation have been relatively large compared to microturbine, diesel, and fuel-cell technologies that are currently being considered. Therefore, the relative cost of a negotiated interconnection agreement per kW or kW-H for the large systems was reasonable. And the cost per kW for a very small machine can be cost-prohibitive.

Today, manufacturers and third-party owners of distributed generators and storage devices are asking for uniform interconnection criteria across technologies (functional rather than device-specific requirements) and testing with certification procedures to determine compliance. Political pressure is building for the principal stakeholders—power companies, equipment manufacturers, DG owners, and government organizations—to come up with the needed standards. Nevertheless, reaching consensus through the voluntary standards process is expected to take time.

Already, standards development has been going on for more than 15 years. In the mid-1980s, the Institute of Electrical and Electronics Engineers (IEEE) sponsored the first interconnection standards for dispersed storage and generation, called DG at that time. The electric power and renewable energy industries gave significant support to this voluntary-standards effort. Fueling the endeavor were the Department of Energy's renewable energy programs. Igniting it was the Public Utilities Regulatory Policy Act of 1978, which made possible the "independent power producer." Several interconnection documents were created and published during the period.

The only standard currently in effect is limited to photovoltaic power systems with requirements specified for systems up to 10 kW: IEEE Standard 929, “Recommended Practice for Utility Interface of Photovoltaic (PV) Systems.” PV systems are typically small, high-tech, and suited for a built-in, “smart” grid interface. IEEE Standard 929 addresses only inverter-connected PV systems. The standard has made a good case for avoiding relatively high-cost, utility-grade relay packages in small, dispersed DC generators that use a smart inverter for connection to the public power supply.

Even so, power producers need an interconnection standard for DG technologies—such as diesel- or gas-driven internal combustion engines, wind-driven induction generators, or the growing family of microturbine power plants. Currently, another universal interconnection standard is being developed, and has been in process since early 1999. Fortunately, records of the earlier efforts and the people involved are providing the catalyst for the new standard. IEEE Project 1547, “Standard for Distributed Resources Interconnected with the Electric Power System,” is now in its third draft. The process is expected to result in a final draft standard by the spring of 2001.

And through these standardization efforts, the terminology continues to evolve. IEEE started with “dispersed storage and generation” (DG), published in the standards in the late 1980s. Then, particularly in California, the term “distributed generation” (DG) began to be used. Today, the evolution of these terms has led to “distributed resources” (DG), which is in the title of the current draft of IEEE Standard P-1547. Definitions proposed by various interests are provided in the latest draft standard as follows:

Distributed Generation – the generation of electricity by facilities sufficiently smaller than central generating plants as to allow interconnection at nearly any point in an electric power system. A subset of distributed resources.

Distributed Resources

Definition #1: A generic term for small sources of electric power that are not a part of a large central power source. Individual sources may be associated with an electric utility grid or with an electric power consumer. These sources may be connected to the system for reliability, voltage control, base-load operation, peak-load reduction, energy recovery, disturbance reduction, or stand-by service.

Potential types of distributed resources are:

- Hydro (water wheel, generator)
- Wind (wind mill, generator, inverter)
- Photovoltaic (solar cells, inverter)
- Solar thermal (steam turbine, generator)
- Geo-thermal (steam turbine, generator)
- Fossil thermal (gas turbine/reciprocating engine, generator)
- Fossil chemical (fuel cells, inverter)
- Stored energy (flywheel, generator)
- Stored energy (battery, inverter)
- Stored energy (magnetic, inverter)

Definition #2: Integrated or stand-alone use of electricity generation, storage, distribution, and end-use or demand-side management (DSM) technologies and/or DSM methods by utilities, utility customers, and third parties in locations that benefit the electric system, specific customers, or both. As applied specifically in this report, the term DG refers only to the generation aspect of this definition and is synonymous with the term *distributed generation*.

Definition #3: Sources of electric power that are connected to the distribution system. They may be connected to the system for reliability, voltage control, base-load operation, peak-load reduction, energy recovery, disturbance reduction, or stand-by service.

Standards activities concerning the interconnection of distributed generation tend to be slow because this is a consensus-building activity among parties with very different motivations. While everyone wants safety and reliability, manufacturers and owners of distributed generation have a strong economic motivation to keep costs down, to standardize the process, to reduce uncertainty, and to speed the interconnection process. The utilities tend to

focus more on assuring continuity of service to other customers and reducing the cost of the overall utility system. Utilities tend to favor studying each installation and are less likely to agree that a generic solution is adequate in all cases. Finding common ground will take more time.

7.C Electrical Power System Fundamentals (witness T. Key)

7.C.1 Electric Power System Overview

The electric power system (EPS) is composed of three distinct parts. From a functional viewpoint these begin with end-use consumption or load, which derive beneficial use from electric energy. Generation fulfills the critical function of producing electric energy that can serve those loads. In this era of deregulation, an end user might look at generation as an own or lease decision. The third part is to transport the electric energy between generation and loads, which is the main function of electrical transmission and distribution. Whatever structures of operations and ownership evolve for the electric power system of the future, these three parts are expected to remain as critical and distinct functions of the EPS.

Looking at the history, electricity has proven to be a convenient, flexible, safe, reliable, economic, and useful form of energy. Widespread electrification in the U.S. was completed early in the 20th century, barely 50 years after the first commercial generating station was built in Manhattan in 1882. The first plants generated direct current (DC) primarily used for electric-arc lamps in cities. By the turn of the century, most plants were alternating current (AC) because transformers provided a convenient method to obtain the higher voltages needed to move electric power greater distances and transformers only work with AC. Also, the AC induction motor was beginning to revolutionize American industry.

One important characteristic of AC power systems is the need for real-time balancing of generation and consumption of both real and reactive power. To accomplish this, some degree of central control is needed. Another characteristic is the special sine wave shape of voltage and current. Mathematically, the sine wave is a linear picture of rotary motion, and in the T&D it is in fact the only waveform besides DC that can deliver energy without changing shape. A third characteristic of AC power systems is its ability to operate with all generators running in synchronism at one chosen frequency. In North America, 60 Hz was

eventually adopted as the standard frequency based on light flicker considerations for electric-arc lamps being used at the time.

As the demand for electricity and the size of the typical power plants increased, the plants moved closer to natural energy resources like coal fields and rivers. Location and economy of large scale reduced the costs of producing electricity. This trend continued with widespread electrification, including all urban areas, and nearly all rural areas by World War II. The main components of the electric power supply evolved to become geographically distributed central power plants interconnected by transmission lines that handle bi-directional power flow and accommodated a networking of generation. From the transmission grid to sub-transmission to distribution, power primarily flowed in one direction from central plants to load centers.

The primary mission of the traditional power system is to produce power in central-generating stations and deliver that power to electrical consumers at their pace of consumption and in ready-to-use form. To effectively carry power to end users, plants are dispersed throughout the utility service territory roughly proportionate to consumption locations and demand. This is the primary requirement of a T&D system: The system must cover ground, reaching every end user with an electrical path of sufficient capacity to satisfy that end user's requirements. Most power delivery systems can be thought of—very conveniently—as composed of several distinct levels of equipment, as illustrated in Figure 7-1.

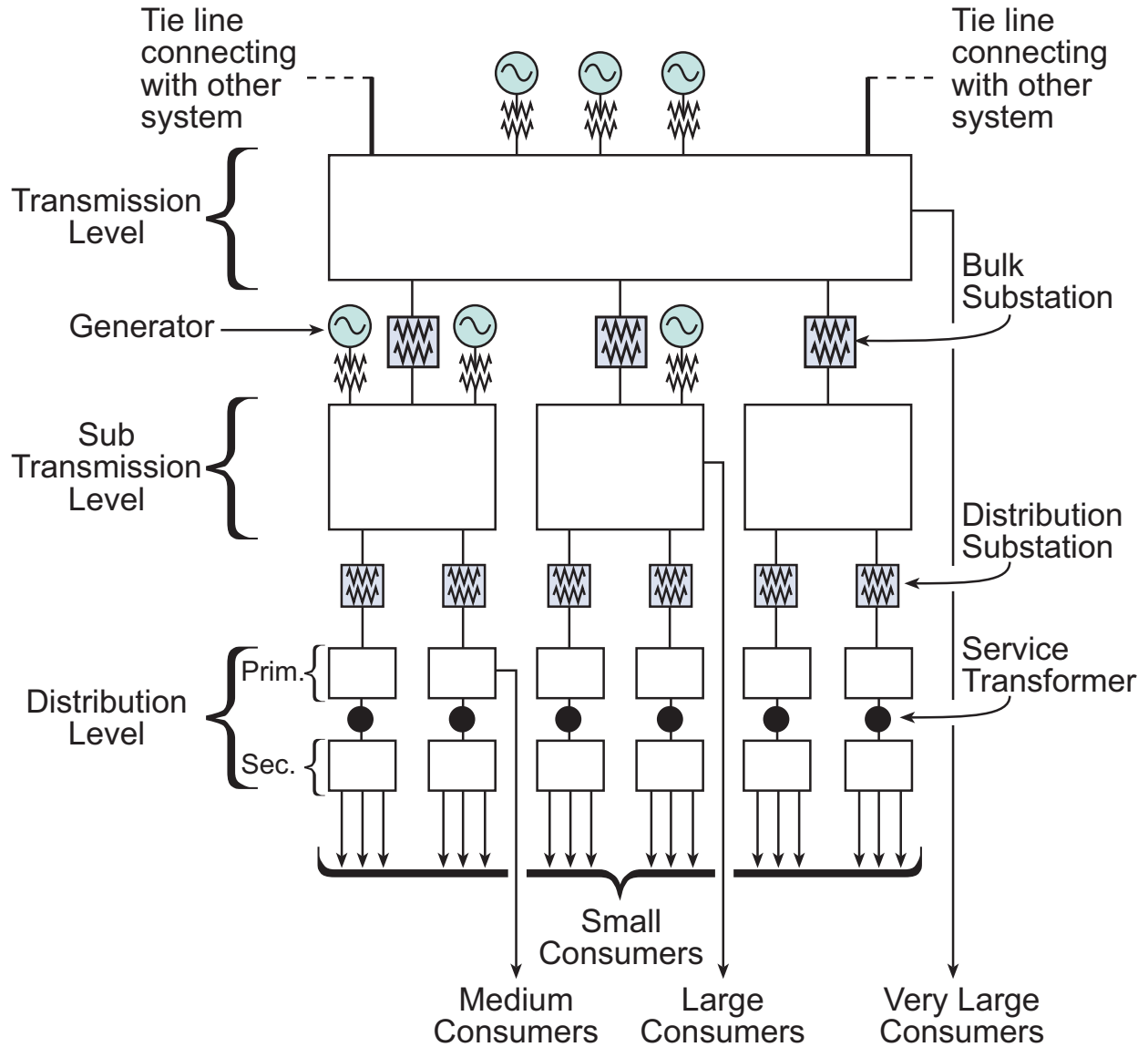

Figure 7-1. Components of traditional vertically-integrated electric power system.

Each level consists of many units of fundamentally similar equipment, doing roughly the same job, but located in different parts of the system. For example, all of the distribution substations are planned and laid out in approximately the same manner, and do roughly the same job. Likewise, all feeders are similar in equipment type, layout, and mission, and all service transformers have the same basic mission and are designed with similar planning goals and to similar engineering standards.

Many of the same characteristics can be found in other large infrastructure systems, such as municipal water systems, natural-gas distribution, and telephone networks. Despite this commonality of characteristics, the operation of electric power systems is fundamentally different from other utilities. Electric systems have two unique physical characteristics:

- Electric energy is not commercially stored² like natural gas and water. Production and consumption (generation and load) must be balanced in near real-time. This requires metering, computing, telecommunications, and control equipment to monitor loads, generation, and the voltages and flows throughout the power system, and to adjust generation output to match consumption.
- The transmission and distribution network is primarily passive, with few “control valves” or “booster pumps” to regulate electrical flows on individual lines. Flow-control actions are limited primarily to adjusting generation output and to opening and closing switches to add, remove, or reroute transmission and distribution lines and equipment from service.

These two operating constraints lead to four reliability consequences with practical implications that dominate power system design and operations:

- Every action can potentially affect all other activities on the power system. Therefore, the operations of all bulk-power participants must be coordinated.
- Cascading problems that quickly escalate in severity are a real threat. Failure of a single element can, if not managed properly, cause the subsequent rapid failure of many additional elements, potentially disrupting the entire power system.
- The need to be ready for the next contingency, more than the current conditions, is factored into operations, and the likely flow that would occur if another element fails, not the present flow through a line or transformer, limits allowable power transfers.
- Because electricity flows at nearly the speed of light, maintaining system stability and reliability often requires that actions be taken instantaneously (within fractions of a second), which requires automatic computations, communications, and controls.

² Electricity is not "stored" directly. When electricity is "stored" it is converted to another form of energy and re-converted later. Pumped storage hydro converts electricity to mechanical potential energy by lifting water. Batteries convert electric energy to chemical potential energy. The re-conversion to electricity uses conventional generators.

When generation consists of large central plants power can be thought of as flowing “down” through these levels, on its way from product manufacturer to consumers. As it moves from the generation plants (system level) to the customer, the power travels through the transmission level, to the sub-transmission level, to the substation level, through the primary feeder level, and onto the secondary service level, where it finally reaches the customer. Each level takes power from the next higher level in the system and delivers it to the next lower level in the system.

a) Transmission Level

The transmission system is a network of three-phase lines operating at voltages generally between 115 kV and 765 kV. Capacity of each line is between 50 MVA and 2,000 MVA. The term “network” means that there is more than one electrical path between any two points in the system, as shown in Figure 7-2. Networks are laid out like this for reasons of reliability -if any one element of the network fails, there is an alternative path, and power is not interrupted. This enables the sharing of generation contingency reserves, greatly reducing the amount of “spare” generating capacity that must be maintained to assure reliability.

In addition to their function in moving power, portions of the transmission system—the major power delivery lines—are designed, at least in part, for stability. The transmission grid provides a strong electrical tie between generators to assure that they remain synchronized. This arrangement allows the system to operate smoothly even with large load fluctuations or generator failures.

Interestingly, DC has returned to the transmission system level. DC transmission lines, with the conversion equipment at each end that couples them to the AC power system, provide one of the few controllable links on the transmission system. Unlike AC transmission lines where the amount of power flowing through the specific line depends on the specific pattern generation injections, load withdrawals, and the configuration of the rest of the transmission and distribution system, the flow on a DC line is controllable. DC lines are expensive, however, so they are installed infrequently.

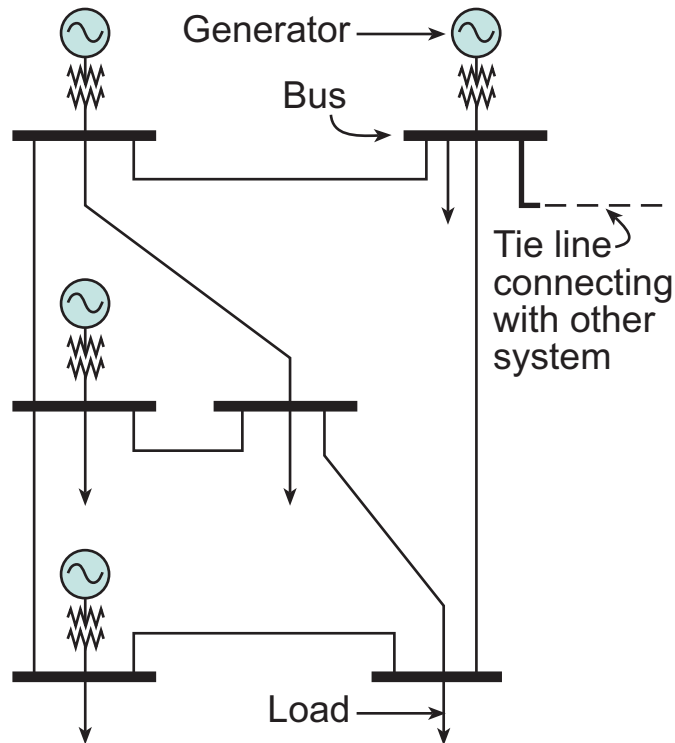

Figure 7-2. Networked system provides for two-way power flow.

b) Bulk-Substation Level

Substations and transformers are required to interface lines or levels that operate at different voltages. The bulk substation level interfaces the transmission and sub-transmission systems. These systems usually form networks, as discussed above, with more than one power flow path between any two parts.

Typically, a bulk transmission substation occupies an acre or more of land, on which the necessary substation equipment is located. Individual substation transformers vary in capacity, from less than 20 MVA to 1200 MVA or more. They are often equipped with tap-changing mechanisms and control equipment to vary their windings ratio and move reactive power between these networks so that they maintain the voltage on the sub-transmission and transmission networks within an acceptable range (typically +5% to -10%).

Very often, a substation will have more than one transformer (two is a common number, and four is not uncommon). Additional transformers usually increase reliability when a transformer can handle much more than its rated load for a brief period (for example, up

to 140 percent of rating for up to four hours). Equipped with from one to six transformers, substations range in capacity from less than 20 MVA for a small, single-transformer substation to more than 2000 MVA for a major tie point.

c) Sub-Transmission Level

The sub-transmission lines in a system take power from the transmission switching stations or generation plants and deliver it to substations along their routes. A typical sub-transmission line may feed power to three or more substations. Often, portions of the transmission system, with a primary function of bulk power delivery and maintaining stability, will also feed a substation along its route. Here the distinction between transmission and sub-transmission lines becomes rather blurred.

Normally, the capacity of a sub-transmission line is in the range of 40 MVA up to perhaps 250 MVA, operating at voltages from 69 kV to as high as 230 kV. With occasional exceptions, sub-transmission lines are part of a network grid—they belong to a system in which there is more than one route between any two points. Usually, at least two sub-transmission routes reach any one substation, so power is maintained if either one fails.

d) Distribution-Substation Level

Substations, the meeting point between the transmission grid and the distribution feeder system, are where a fundamental change takes place within most T&D systems. The transmission and sub-transmission systems above the substation level usually form a network, as discussed above, with more than one power flow path between any two parts. But from the substation on to the customer, the network configuration is no longer maintained due to the high cost. Thus most distribution systems are radial and only one path reaches most end users (networked distribution systems are used in urban areas where load density and reliability concerns warrant it).

Individual substation transformers typically vary in capacity, from less than 5 MVA to over 50 MVA though some are as large as 165 MVA. They are often equipped with tap-changing mechanisms and control equipment to vary their windings ratio so that they maintain the distribution voltage within a narrow range, regardless of larger fluctuations

on the sub-transmission side. The distribution voltage, provided on the low side of the transformer, needs to stay within a narrow band of perhaps only ± 5 percent.

Very often, a substation will have more than one transformer (two is a common number, and four is not uncommon). Additional transformers usually increase reliability when a transformer can handle much more than its rated load for a brief period (for example, up to 140 percent of rating for up to four hours). Equipped with from one to six transformers, substations range in capacity from as little as five MVA for a small, single-transformer substation, serving a sparsely populated rural area, to 150 MVA or greater with multiple transformers serving a very dense area within a large city.

e) Feeder Level

Feeders—whether overhead distribution lines mounted on poles or underground—route the power from the substation throughout its service area. Feeders operate at the primary distribution voltage. The most common primary distribution voltage in use throughout North America is a 15-kV class, although voltages anywhere from 4160 V to 34.5 kV are used. Some distribution systems use several primary voltages, for example, 23.9 kV, 13.8 kV, and 4.16 kV.

A feeder distributes between 2 MVA to more than 30 MVA, depending on the conductor size and the distribution voltage level. From two to 12 feeders may emanate from any one substation, with three to four probably the most common. The feeder configuration is characterized by repeated branches as the feeder moves out from the substation toward the customers, as shown in Figure 7-3.

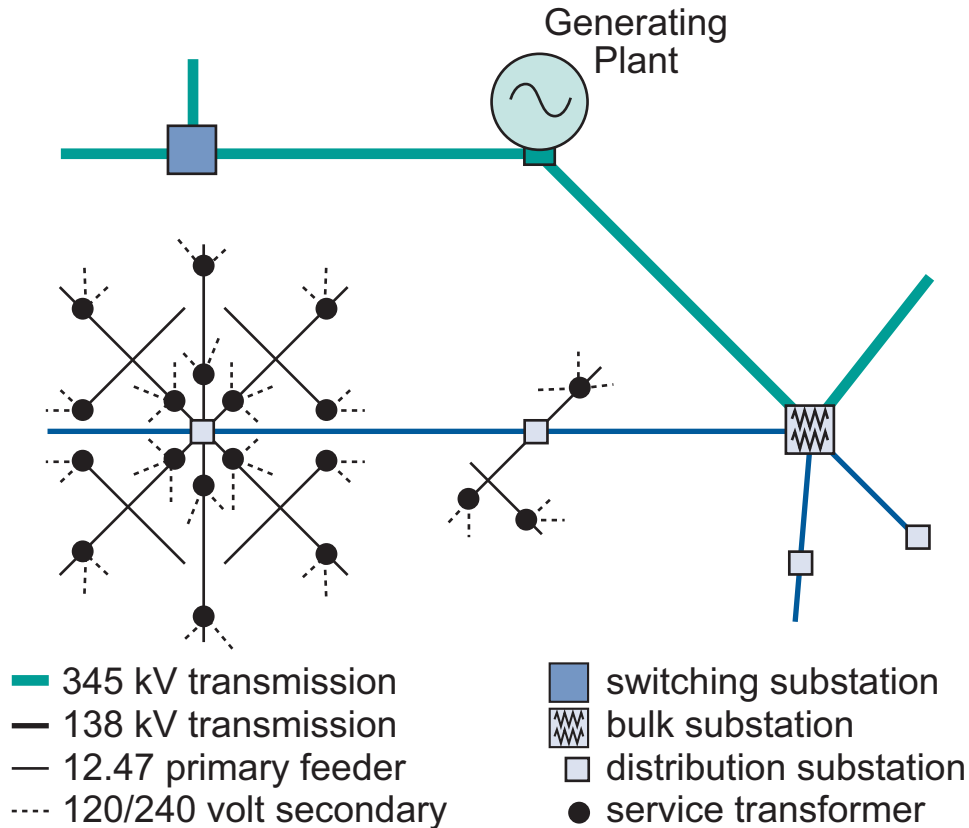

Figure 7-3. Power flow via feeder system from central station to end users.

By definition, the feeder consists of all primary voltage level segments between the substations and an open point (switch). Any part of the distribution-level voltage lines – three-phase, two-phase, or single-phase--that is switch-capable is considered part of the primary feeder. The primary trunks and switch-capable segments are usually built using three phases. The largest size of distribution conductor – typically about 500-600 MCM (MCM is cross-section of the conductor in thousand circular mils) but as large as 2,000 MCM – is used for reasons other than just maximum capacity (for example, contingency switching needs). Often a feeder has excess capacity because it needs to provide backup for other feeders during emergencies.

The vast majority of distribution feeders are overhead-constructed on wooden poles (or concrete) with wooden cross-arms or post insulators. Only in dense urban areas, or in situations where esthetics are particularly important, can the higher cost of underground construction be justified. In this case, the primary feeder is built from insulated cable,

which is directly buried or pulled through concrete ducts that are first buried in the ground. An underground feeder is from three to ten times the cost of an overhead feeder.

Many times, the first several hundred yards of an overhead primary feeder are built underground, even if the rest of the system is overhead. This reduces congestion and improves aesthetics around the substation. The underground feeder getaway usually consists of buried, ducted cable that takes the feeder out to a riser pole, where it is routed above ground and connected to overhead wires. Very often, this initial underground link sets the capacity limit for the entire feeder—the underground cable ampacity is the limiting factor for the feeder’s power transmission.

f) Lateral Feeds

Laterals may be short line segments that branch off the primary feeder to make the final primary voltage connection from the feeder substation to the customer service transformer. The design of most radial feeder systems in North American use single- and two-phase laterals to deliver power over short distances. Tapping off only one or two phases of the primary feeder minimizes the amount of wire that is needed for small numbers of end users not requiring all three phases.

Typically, laterals deliver from as little as 10-kVA for single-phase residences to as much as 2 MVA. In general, even the largest laterals use relatively small conductors (compared to the primary size). When a lateral must deliver a great deal of power, the planner will normally use all three phases, with a relatively small conductor for each, rather than employ a single phase and use a large conductor. This approach avoids creating a significant imbalance in loading at the point where the lateral taps into the primary feeder. Power flow, loadings, and voltage are maintained in a more balanced state if the power demands are distributed over all three phases.

7.C.2 Attributes of Traditional Vertically Integrated Utility System

Each level in an electric system is fed by the one above it, which assumes that the next higher level is electrically closer to the generation. Both the nominal voltage level and the

average capacity of equipment drops from level to level moving from generation to customer. Transmission lines operate at voltages between 115 kV and 765 kV and have capacities between 50 and 2,000 MW. Sub-transmission lines operate between 69 kV and 230 kV with capacities from 40 MVA to 250 MVA.

By contrast, distribution feeders operate between 5 kV and 35 kV, and have capacities somewhere between 1 and 40 MW. Of course voltage level and the level of power delivery as well as the practical distance are related. The most common distribution voltage in the US is 12-14 kV. At this voltage level in densely populated areas one substation may cover only a few square miles. A typical distribution substation in the suburbs might cover 10-50 square miles, while a rural area station is likely to serve more than 100 square miles.

It is interesting to note that each level has more pieces of equipment in it than the one above. A system with 300,000 customers might have 50 transmission lines, 100 substations, 600 feeders, 40,000 service transformers, and 300,000 metered service entrances. As a result, the net capacity (number of units times average size) is highest near the customer. A power system might have 4,500 MVA of substation capacity but 6,200 MVA of feeder capacity and 9,000 MVA of service transformer capacity installed. With more components and more exposure reliability usually drops as one moves closer to the customer. Typically, 60% of service interruptions are a result of distribution equipment upset or failure within ½ mile of the consumer.

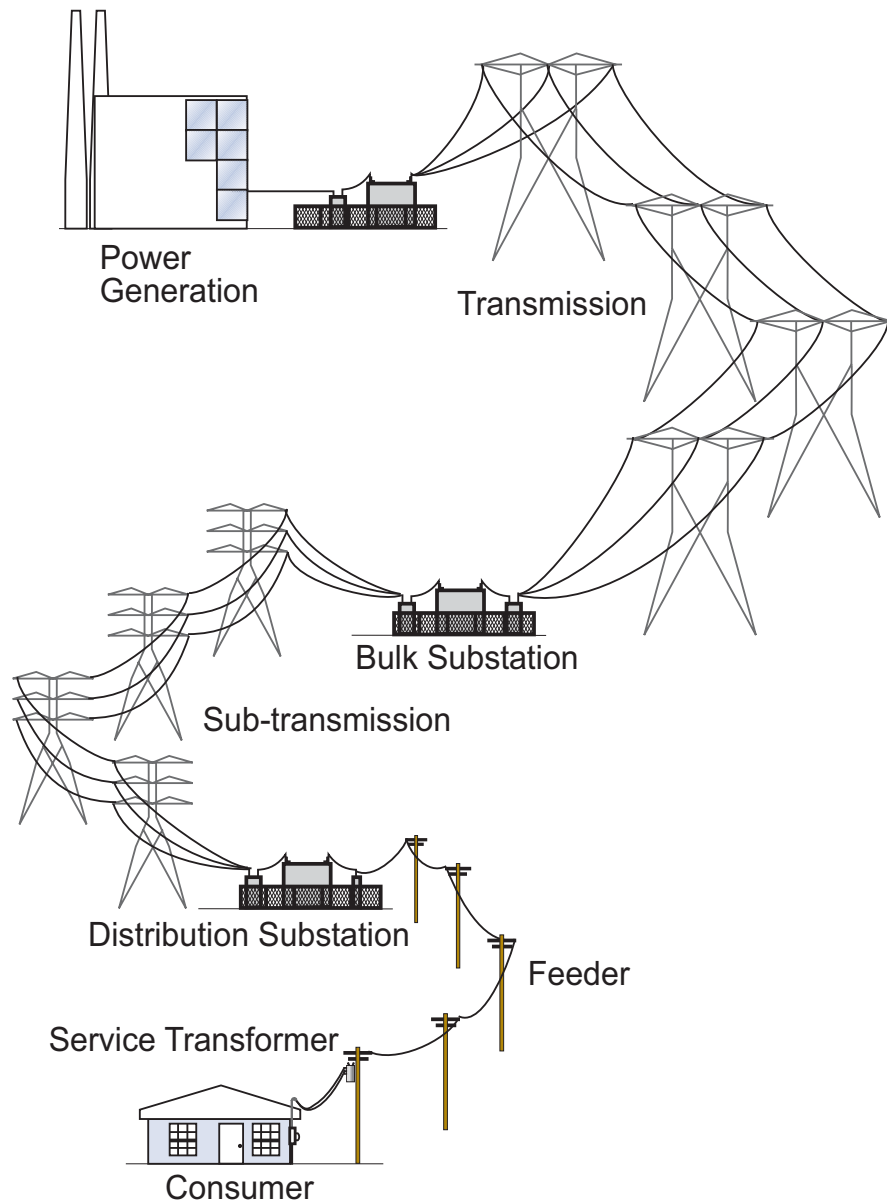

Figure 7-4. Traditional vertically-integrated electric power system.

7.C.3 Electric Power System Future Structure

Restructuring is changing the electric power system. The same physical laws still apply and the same functions must be performed to maintain performance and reliability. But changes are occurring in the commercial activity that the system is being asked to support and in the commercial nature of the entities that supply, operate and utilize the electric power system. The traditional view of a vertically integrated EPS needs to be updated to include the

possibility for more distributed generation and more business possibilities at various levels in the system.

Figure 7-5 shows the expected five-layer structure of the EPS in California. Functions are less vertically integrated than in the traditional EPS. Commercial activity between generators and loads occurs at more levels, and may or may not rely on services from multiple levels. With greater diversity in the location of generation, more options exist for supporting reliability. And the role of the T&D varies in different areas of the system depending on the relative size and location of load and generation in that area. A restructured electric power system supports more diversity in generation and load commercial activity at all levels.

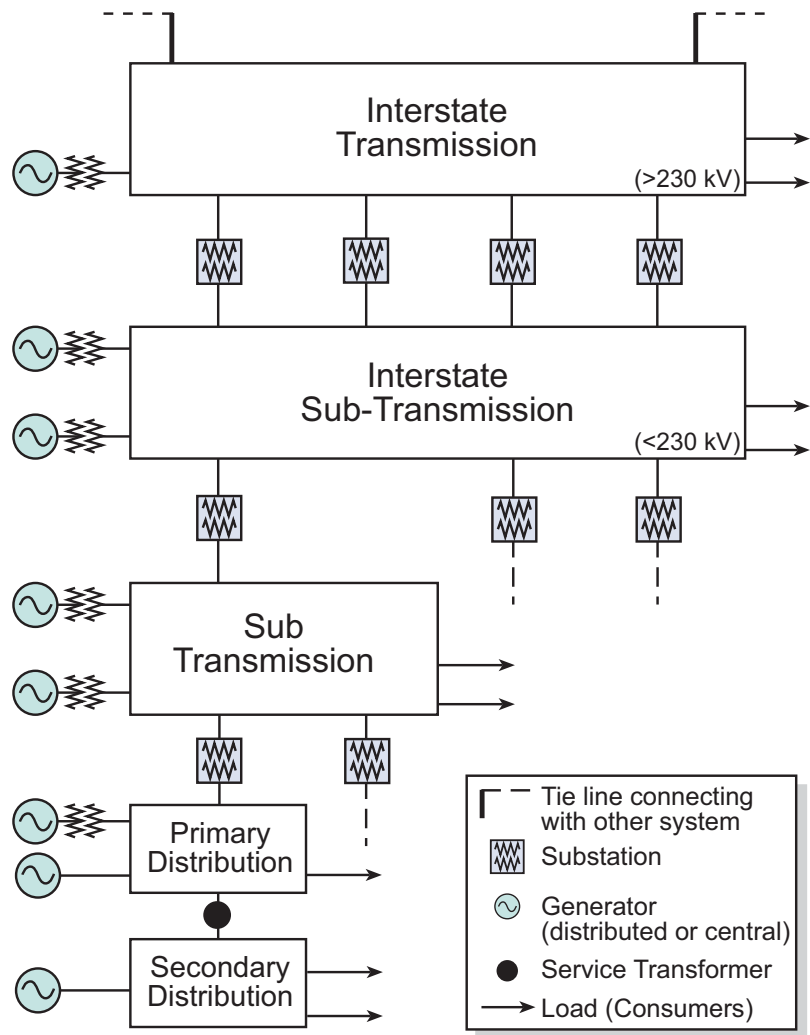

Figure 7-5. Restructured EPS with Distributed Generation in California.

7.C.4 End-Use Consumption Component

Activities near the point where electricity is ultimately utilized constitute the End Use Consumption component. Historically, this would include only load, and that load would have minimal interaction with the power system other than to consume needed energy. Some end users would control loads to limit demand, others would schedule operations around time-of-use tariffs. In both cases, load control was based upon fixed schedules, not current electricity market conditions or transmission and distribution system loading conditions. Restructuring, advances in communications and controls, and the emergence of competitive distributed-generation technologies now make it possible for the end user to interact dynamically with the power markets and power system.

Distributed generation can supply part of the local load, reducing the loading on the transmission and distribution system. This can reduce congestion or eliminate the need for T&D enhancements³. Distributed generation can also supply energy and/or ancillary services back to the power system.

a) Key Elements that Compose End-Use Consumption

The key elements that make up end-use consumption are devices that transform electricity into other, directly useable products including heat, cooling, mechanical motion, light, sound, information technologies etc. Based on International Electro-technical Commission (IEC) Standards these devices may be grouped into nine categories:

- household, commercial equipment
- industrial equipment
- information technology equipment
- telecommunications equipment
- radio, TV and similar equipment
- traffic and transportation equipment

³ Transmission and distribution enhancements include any modification to the transmission and distribution system that increases its capacity. Examples include adding new lines, upgrading existing lines, replacing transformers, installing flexible AC transmission (FACTS) devices, etc.

- utilities equipment (gas, water, ...)
- medical equipment
- measurement and test equipment.

b) Functions of End-use Consumption

The basic and critical function of the end-use consumption component in the electrical power system is to transform electric energy into other forms that provide useful work or services that are considered by the end user to have a higher value than the cost of the electric energy.

Incorporating both the technical and practical commercial aspects, this definition is consistent with IEEE's and Webster's dictionary. For example the IEEE defines end-use load, with respect to electrical utilization, as the "as electric power used by devices connected to an electric generating system," load is also defined as demand or energy. Webster's dictionary defines consumption as "the utilization of economic goods in the satisfaction of wants or in the process of production, and resulting in their destruction, deterioration, or transformation."

c) Types of End-use Consumption

The interconnection of end-use load equipment with the electric power system is important to the reliability and quality of the power. Wherever end use equipment is operating it becomes part of the electric power system. Its steady-state performance and transient behavior affect the supply and other nearby equipment. Specific end-use load characteristics such as harmonic current distortion, inrush current, high-frequency emissions, and immunity define the compatibility between the power supply and end-use consumption.

The main generic load types based on technology are electromechanical (induction and synchronous motors), electromagnetic (induction coils and ballasts), resistive (heating elements and lights), and non-linear (micro and power electronics). Of these, motors are the largest single user of electricity. The fastest growing load type in all sectors, residential, commercial and industrial, is non-linear. These loads encompass the proliferation of electronic appliances, and they include PCs, electronic lighting,

adjustable-speed drives, entertainment equipment, and inverters as may be used in some distributed generation systems. Figure 7-6 show how energy use is divided among the main end-use sectors.

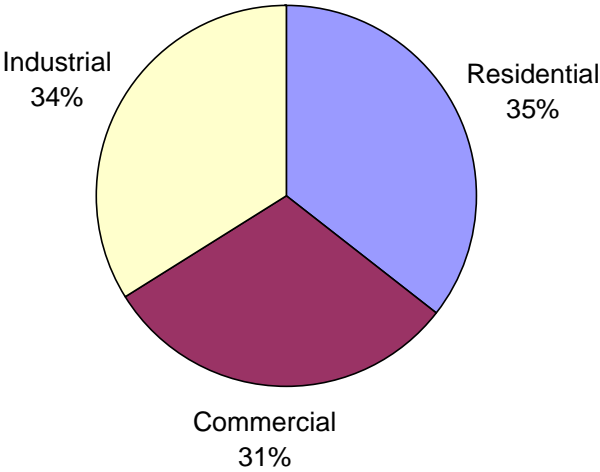

Figure 7-6. U.S. Electrical consumption by end-use sector (1997 DOE).

7.C.5 The Generation Component

Electricity does not occur naturally in a form that can be readily collected for commercial use. Instead, electric energy is obtained from some other available primary energy. This is accomplished in power plants using energy-conversion apparatus. The most common form of primary energy used in electric power plants is fossil fuel, such as oil and coal. Energy from nuclear fission and from moving water is also frequently harnessed. Less common, but environmentally popular resources are wind, solar, geothermal, and waste-heat energy.

“Power generation, in the electric utility industry, means the conversion of energy from a primary form to the electric form. Nearly all the electric energy distributed by utilities comes from: the conversion of chemical energy from fossil fuels, nuclear fission energy, and kinetic energy of moving water as it falls through a difference of elevation.

Heat energy, obtained from the combustion of fossil fuels or the fission of nuclear fuels is converted to mechanical energy through the rotating shafts of steam turbines, combustion turbines, or internal combustion engines. These shafts in turn drive electric generators.”⁴

⁴ From: Homer M. Rustebakke et.al. 1983, *Electric Utility Systems and Practices, Fourth Edition, Chapter 3, pg 27, John Wiley & Sons*

a) Key Elements that Compose Generation

The three key elements that make up an electric generating plant are:

1. Energy resources or fuels such as oil, natural gas, wind, and sunlight.
2. Generating plant apparatus to convert the primary energy into a more useful form. Boilers, cooling towers, and turbines convert heat to mechanical energy. Dams, turbines, and water wheels convert the potential energy of water into the mechanical movement of the hydro-electric generator. On a smaller scale, the silicon junction of a photovoltaic cell and its related structure and cooling systems are the plant equipment needed to convert solar energy into DC electricity.
3. The electromechanical machine (or generator) that converts mechanical energy, and the electronic converter (or inverter) that converts DC electric energy to a continuous AC power output.

Because all the different forms of primary energy are ultimately converted to 60-Hz electric power, the conversion steps have important consequences for the electric power system. For most generating plants, the first step is conversion to mechanical energy. In the U.S., about 80 percent of the primary energy is converted to mechanical energy via the steam cycle, where fossil and nuclear fuels are expended to boil water and drive a turbine. Most of the remaining 20 percent of energy resources are converted to mechanical energy from moving water over a water wheel, and combustion of fuels in the internal combustion engine or in combustion turbines. Electrical generation is then achieved by converting the mechanical energy into alternating-current electric power via a synchronous generator.

The mix of fuel use and of utility and non-utility ownership of generation provide an interesting contrast with the rest of the country. Table 7-1 shows the nameplate capacity of major generation by primary fuel type in the United States and in California as of January 1, 1999. Overall in the US 88 percent of the nameplate generation is owned by utilities. In California, approximately 57 percent is utility owned (31,000 MW) and 43 percent (23,000 MW) is non-utility owned.

Table 7-1. Utility-owned nameplate generation by fuel type (January 1, 1999).

<i>Fuel/Plant Type</i>	<i>Capacity US (MW)</i>	<i>%</i>	<i>Capacity CA (MW)</i>	<i>%</i>	<i>% CA to US</i>
Coal	320593	44.0%	0	0.0%	0.0%
Petroleum	69812	9.6%	891	2.9%	1.3%
Natural Gas	135426	18.6%	10729	34.6%	7.9%
Hydroelectric Pumped Stg	18071	2.5%	3352	10.8%	18.5%
Hydroelectric	73085	10.0%	9530	30.8%	13.0%
Nuclear	104757	14.4%	4555	14.7%	4.3%
Waste Heat	4035	0.6%	287	0.9%	7.1%
Multi-Fuel	221	0.0%	0	0.0%	0.0%
Other Renewable	2246	0.3%	1639	5.3%	73.0%
Total industry	728246	100.0%	30983	100.0%	4.3%

In Table 7-2 the nameplate capacity of major generation by primary fuel type in the United States and in California is shown as of December 31, 1998. From the two tables combined it can be seen that California has 6.6 percent of the generation resources in the country. The state is very high in generator capacity from renewable sources and very low in generation from coal. California is at the national average in its nuclear plant capacity.

Table 7-2. Non-utility owned nameplate generation by fuel type (December 31,1998).

<i>Fuel/Plant Type</i>	<i>Capacity US (MW)</i>	<i>%</i>	<i>Capacity CA (MW)</i>	<i>%</i>	<i>% CA to US</i>
Coal	13712	1.9%	206	0.7%	1.5%
Natural Gas	37325	5.1%	13254	42.8%	35.5%
Petroleum	2629	0.4%	296	1.0%	11.3%
Petroleum/Gas (combined)	23310	3.2%	4959	16.0%	21.3%
Hydroelectric	4136	0.6%	501	1.6%	12.1%
Geothermal	1449	0.2%	1188	3.8%	82.0%
Nuclear	0	0.0%	0	0.0%	0.0%
Solar	385	0.1%	354	1.1%	91.9%
Wind	1689	0.2%	1480	4.8%	87.6%
Wood	6887	0.9%	616	2.0%	8.9%
Waste	3488	0.5%	351	1.1%	10.1%
Other Renewable	3075	0.4%	308	1.0%	10.0%
Total industry	98085	13.5%	23513	75.9%	24.0%

Source, Inventory of Electric Utility Power Plants in the United States 1999, DOE/EIA-0095(99), November 1999.

b) Functions of Generation

The main function of generation is to produce electric energy to serve those loads. This function includes regeneration from stored energy. Several other critical sub-functions of the generation component in an electric power system are:

- To produce electric energy from other forms of energy.
- To provide controllable power injections that the system operator can use to balance generation and load in real-time.
- To provide controllable reactive power injections and withdrawals that the system operator can use to control voltages within the power system and meet the real-time reactive power demands of loads and the power system itself.

These functions and sub functions are consistent with the IEEE dictionary, which defines generation as the production or storage of electric energy with the intent of enabling practical use or commercial sale of the available energy. The IEEE dictionary also defines a generating station as “a plant wherein electric energy is produced from some other form of energy (for example, chemical, mechanical or hydraulic) by means of suitable apparatus.”

c) Types of Electric Generators

The reason to look a bit closer at the electric generator technology is that the generator makes the connection with the public power supply. The operating and performance characteristics of the generator will determine many of the capabilities and limitations for the electric power system. New energy sources and applications are requiring many different power plant technologies. Still we can classify nearly all AC electric power generators into four main technologies: synchronous generators, induction generators, self-commutated inverters, and line-commutated inverters.

Far and away, the synchronous generator is the primary power producer in electric power systems. Only a relatively small quantity of electric energy is currently converted through other types of generators. All large plants utilize synchronous machines. Fuels include coal, oil, natural gas, biomass, and nuclear. Also, direct sources of heat such as geothermal, solar, or waste heat from another process typically produce steam. The steam is used to turn a turbine that drives a synchronous generator. Alternatively, natural gas or oil can fuel a combustion turbine where hot gas turns the turbine that drives the synchronous generator. Large hydro generators use flowing water to rotate a synchronous generator. Generators driven by internal combustion engines (large or small) are typically synchronous machines.

Despite the dominance of the synchronous generator in production of electric power, new energy resources demand additional conversion methods. For example, fuel cells and photovoltaic energy sources are fundamentally different in that they do not require a mechanical energy step. Electricity is generated directly in the form of direct current (DC), and there is no need for electromechanical conversion. An electronic inverter is required to convert the DC to AC power and feed the energy into the grid.

Small combustion turbines provide a variable-speed mechanical output. The most common converter to electricity is a permanent-magnet version of the synchronous generator. However, the electric output is variable frequency and typically at a much higher frequency than the 60-Hz used for commercial power in the U.S. This variable-frequency AC is then rectified to DC. Electronic inverters are needed to convert the DC electricity into AC power of the desired frequency and voltage.

Another way to convert variable-speed mechanical energy that comes from a wind turbine or a small water turbine is the induction generator. This machine will generate AC current into the electric system as long as the mechanical speed of the turbine exceeds the synchronous frequency of the induction machine and electric system. Thus the synchronous generator, rectifier, and inverter are not needed.

Synchronous Generators. An electromagnet or a permanent magnet on the rotor produces the magnetic field in a synchronous generator (see Figure 7-7). As a consequence, the frequency of the AC electric power produced (60-Hz, for example) is exactly related to the rotational speed and number of poles of the generator rotor (1800 RPM and 4 poles, for example). Similarly, the magnitude of the voltage produced (and the reactive power delivered to the power system or consumed by the generator) is directly related to the strength of the magnetic field in the rotor. A wound-rotor synchronous generator with rotor field current control can regulate its own output voltage as well as the ratio of real to reactive power.

Synchronous Generators

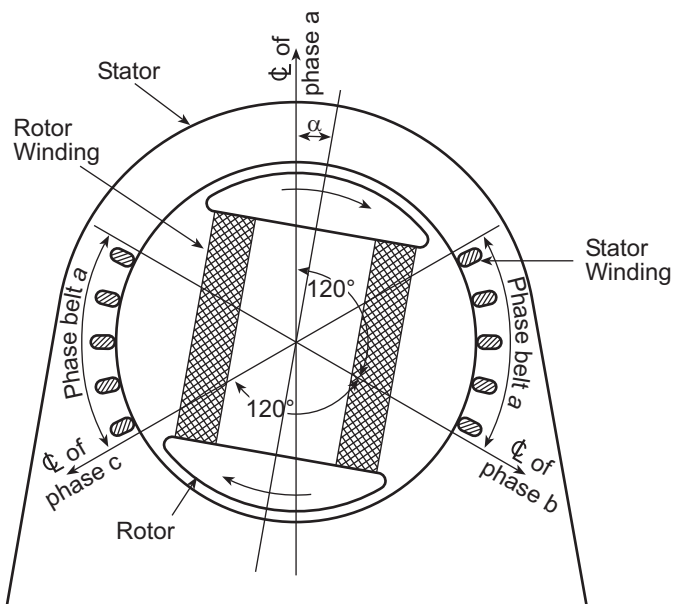

Figure 7-7. The conventional synchronous AC generator produces more than 99% of all electricity generated in the United States.

Synchronous generators are excellent for supplying isolated loads or for operating in synchronism with a larger electric power system. Synchronous generators have relatively high surge capacity, which is useful for supplying momentary overloads and also produces higher current into a system fault. They can also produce reactive power to energize the delivery systems and allow stable power transfer, regulate the generator's output terminal voltage, and provide needed reactive power to nearby loads.

Induction Generators. An induction generator differs from a synchronous generator in that it relies on the power system to induce the required magnetic field in the rotor. This field is induced based on the relative difference in speed between the machine rotor and the power system frequency. This difference is also called slip. The slip increases with machine loading. As a generator, the induction machine rotor is driven faster, and as a motor, the rotor is slower than the synchronous speed for the machine and power system (900 if 6-pole, 1800 if 4-pole, and 3600 if 2-pole at 60 Hz).

As a consequence, the generator mechanical speed cannot operate in synchronism with the power system frequency because there is no field induced when the rotor speed is

the same as the synchronous speed. In order to generate electricity, the machine must run faster than synchronous speed. For example, a 4-pole machine in a 60-Hz power system generates at speeds between 1820 and 1860 RPM, where 1800 RPM is synchronous speed. Wind and micro-hydro facilities typically use induction generators because the uncoupling of the electrical and mechanical speeds enhances power transfer.

An induction generator consumes rather than generates reactive power and cannot control its output voltage. Consequently, induction generators are not good at supplying isolated loads. Even so, there is no guarantee that an induction generator will not support an isolated or “islanded” system. If there is just the right amount of capacitance and real load in the island, the induction machine can generate electricity. Induction generators have lower surge-current capacity than synchronous generators, so their ability to support a momentary overload is reduced. The output drops rapidly as voltage collapses, so they have relatively low fault contribution.

Self-Commutating Inverters. Inverters convert DC electricity to AC power by switching DC power through a bridge circuit arrangement at the desired frequency and with alternating polarity. Fundamentally, all inverters must do three things: invert, regulate, and shape the output. A self-commutated inverter is able to invert by commutating switches on and off in order to reverse current in both directions. With on/off switching control, a self-commutating inverter can control frequency. Many self-commutated designs are also able to regulate and shape the output current using switching techniques such as pulse-width-modulation. In this regard, the self-commutated inverters act like a synchronous generator and are able to supply real and reactive power, suitable for powering isolated or interconnected loads.

Most inverters have a relatively low overload capability, typically limited to 2 to 3 times normal rated output. Switching to produce AC from DC will create distortions in the output voltage and current waveforms. The waveforms and the frequency of the harmonics that comprise the distortions depend on the switching frequency, output filtering, and inverter technology. Typically these inverters are designed to maintain unity power factor and harmonic distortions of 5 to 10 percent.

Line-Commutated Inverters. A line-commutated inverter also uses a bridge configuration to invert DC power. Devices are typically turned on by a signal from the inverter control. However, these devices rely on the power system voltage to force the output current through zero and to turn off the switch, hence the term “line-commutated.” As a consequence, the inverter frequency follows the line frequency, and it is usually not practical to provide voltage regulation. The inverter consumes reactive power, and is not suitable to power isolated loads. Even so, like the induction generator, the line-commutated characteristics cannot be relied upon to guarantee a shutdown when in an islanded load situation. Tests have shown that with the right amount of capacitance and real load, the line-commutated inverter can continue to energize an islanded system.

Like other inverters, overload capability is limited. Line commutation does not allow for direct wave-shaping by modulating switching frequency. Therefore, harmonic distortions will be higher than in the self-commutated inverter, in the range of 10 to 50 percent unless filters or transformers are added to trap and cancel harmonics. Also, the line-commutated inverter may operate in a mode where current is discontinuous, creating both high- and low-frequency harmonics.

d) Auxiliary Losses within the Generation

The portion of the generated energy that is used in the generation process is called *auxiliary energy losses* or *plant losses*. These losses can be calculated by subtracting the net plant output from the gross energy generation. This includes energy used to run motors driving various pieces of equipment such as pumps and fans, lighting, controls, space conditioning, and any other functions required to keep the plant running.

7.C.6 Transmission and Distribution Component

The function of transmission and distribution is very simple: to transport electric energy from the generator to the load. A system with a single generator and a single load would have a very simple transmission and distribution system, possibly consisting of little more than a single cable with some sort of fault protection. At a minimum, transmission and distribution allow generation to be physically remote from the load. Through the interconnection of load and generators, T&D provides many reliability and economic

benefits. The working definitions of transmission and distribution vary greatly among different areas and companies. Usually three main distinctions are made:

1. By voltage class: Transmission operates at higher voltages while distribution operates at lower voltages.
2. By function: Transmission facilitates bulk power movement from the place of generation to wide areas of end-use consumption, while distribution delivers power to users within that area.
3. By configuration: Transmission is generally networked while distribution is primarily radial.

a) T&D Reliability Benefit

Because electricity cannot be stored and because generators are not perfectly reliable, it is beneficial to have additional generating capacity available, ready to respond immediately if a generator fails unexpectedly. Simultaneous failure of multiple generators is unlikely, so a single extra generator can provide reliability reserves for multiple generators if a transmission and distribution system is available to move power from the reserve generator to the place it is needed.⁵ In practice, “extra” generators are not typically used to provide the primary reliability reserve. Instead, reserve capacity is made available on many generators. Still, the role of transmission and distribution in facilitating reliability is the same.

Historically, utilities interconnected multiple generators with load centers through transmission and distribution networks to increase reliability. Later, they interconnected multiple utility systems to share reliability support over larger geographic areas. Today, there are three major interconnections that cover the entire Continental United States, most of Canada, and parts of Mexico. California is part of the Western Systems Coordinating Council (WSCC), one of ten North American Electric Reliability Council (NERC) councils, and one of the three interconnections.

“WSCC is the largest geographically of the ten Regional Councils. The Council’s 1.8 million square mile service territory is equivalent to more than half the contiguous area

⁵ Different types of reliability reserves are discussed more fully as Ancillary Services later.

of the United States. WSCC was formed in 1967 and at the close of 1998 had a membership of 108 organizations that includes transmission dependent utilities, major transmission utilities, independent power producers, marketers, and a regulatory agency. Members provide reliable service to over 65 million people in all or part of Arizona, California, Colorado, Idaho, Montana, Nebraska, Nevada, New Mexico, Oregon, South Dakota, Texas, Utah, Washington, and Wyoming, as well as the Canadian provinces of Alberta and British Columbia, and the northern portion of Baja California, Norte, Mexico.”⁶

b) T&D Load Diversity Benefit

Aggregating loads through the transmission and distribution system also has benefits. Individually, loads tend to fluctuate dramatically. Short-term fluctuations (faster than 10 minutes), for example, tend to be random among loads. By interconnecting many loads together, the transmission and distribution system presents a net load to the generators that is much less erratic and therefore easier (and cheaper) to follow. For example, 100 homes aggregated together present only 10 times the regulation burden that one home presents.

c) T&D Economic Benefit

Transmission and distribution systems contribute to reducing operating costs as well as increasing reliability. With large numbers of generators and loads connected together, it is possible to operate the most economic mix of generation needed to serve the changing load at any given time. This is made possible by networking and providing for dynamic power transfer from generation sources to end-use consumption points as required to maintain system energy balance.

The most economic mix of generation can be selected through traditional centralized least-cost economic dispatch (as was done historically) or through market-based competition (as is done in California today). In either case, the ability to adjust the mix of generation to economically accommodate different load patterns is facilitated by the transmission network.

⁶ From the NERC web site, <http://www.nerc.com/regional/wsc.html>, accessed on 3/21/2000.

d) Key Elements that Comprise T&D

The key elements that comprise a transmission and distribution system are:

- Transmission and distribution lines are used to electrically connect separated generators, transforming stations, and load centers.
- Substations (where transformations occur) link transmission lines with sub-transmission lines and sub-transmission lines with distribution lines.
- Transformers are used to change system voltages. They step up the central-station generator voltage for transmission and they step down the voltage for distribution lines and end-use consumption.
- Capacitors are used at strategic locations throughout the transmission and distribution system to raise unacceptably low voltages in discrete steps.
- Inductors are used in a similar fashion to hold excessive voltages down.
- Switches are used to put pieces of equipment (lines, transformers, generators, capacitors, and so on) in and out of service.
- Circuit breakers are switches that can perform switching functions in the presence of very high currents resulting from short circuits and are therefore used for fault clearing.
- Fuses are designed to interrupt an overload or fault current. Like circuit breakers, fuses are used for clearing faults by isolating the faulted portion of the system from the unfaulted portions.
- Relays are the devices that sense short circuits or other abnormal conditions defined in the system protection scheme. They direct circuit breakers or circuit reclosers to open and eliminate the short circuit. Relays may also allow reclosing or transfer to restore power.

In the restructured electric service industry, transmission and distribution facilitate commerce between generators and end-use consumption. To facilitate this commerce reliably, the power system operators must have sufficient transmission and distribution resources available to transport generated energy to meet end-use consumption

requirements The power system operator must also have the ability to exercise control over generation (and load) when commercial activity threatens power system reliability.

e) T&D Jurisdiction

The U.S. Federal Energy Regulatory Commission (FERC) has identified seven distinctions that test whether a part of the power system is under its jurisdiction, and thus available to open access and wholesale markets under FERC rules, or whether it is “local distribution,” and thus under the jurisdiction of states (Order 888). These seven characteristics of local distribution as shown below are a fairly good test of whether equipment and facilities are transmission or distribution in any power system.

- Local distribution system is normally in close proximity to retail customers.
- Local distribution system is primarily radial in character.
- Power flows into local distribution; it rarely, if ever, flows out.
- Power on the local distribution system is not transported to another market.
- Power on the local distribution system is consumed in a comparatively restricted geographical area.
- Meters at the interface from transmission to distribution measure the flow into the distribution system.
- Local distribution is of reduced voltage compared to the transmission grids.

f) Functions of Transmission and Distribution

The critical function of T&D in the electric power system is:

- The transport of electric energy between loads and generation. Through the T&D facilities that interconnects the generators and consumers in the EPS significant additional benefits are derived from T&D. These may be considered as critical sub-functions of T&D:
- Enabling the most economic mix of generation at different locations in the system to meet the instantaneous system load requirements.
- Providing for the aggregation a large number of independent end-use loads leading to a less fluctuating net load that is easier and more economic to serve.

- Providing for the aggregation of a large number of independent generators leading to increased EPS reliability and reduced operating cost.

Again these this functional designation is consistent with the IEEE, which defines transmission system as “an interconnected group of electric transmission lines and associated equipment for the movement or transfer of electric energy in bulk between points of supply and points for delivery.” Distribution system is defined as “that portion of the electric system which delivers electric energy from transformation points on the transmission or bulk power system to the consumers.” The distribution substation in power operations is identified as a “transforming station where the transmission is linked to the distribution system.”

Also provided within the T&D component is the system operation and control activity. This activity involves planning and control of the minute-by-minute balance of system generation to meet end-use consumption requirements, which also includes the control of several “ancillary services” that facilitate the real-time balancing of generation and load.

g) Types of Transmission and Distribution

There are three fundamentally different ways to layout T&D to provide the required functions. These are radial, loop, and network design configurations. In this discussion a closed loop system is considered to be a simple network. The transmission is networked for reasons described above. Distribution is normally operated in a radial configuration. However, distribution has some interesting variations, including loop and network, that may impact the deployment of distributed generation. The variations are primarily related to protection, options for contingency reconfiguration, and interconnection with the rest of the power system. Figure 7-8 shows the basic layouts of distribution radial, loop, and network systems.

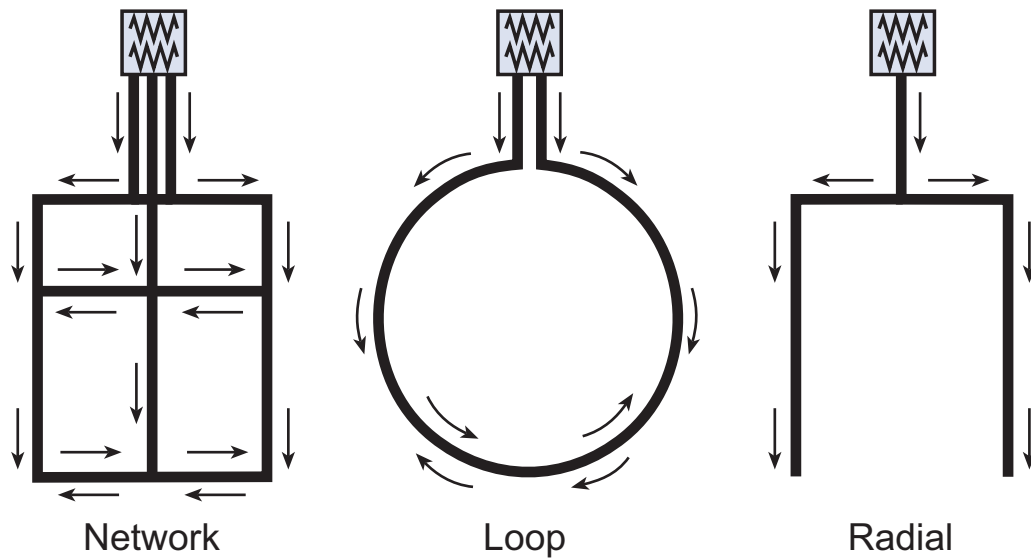

Figure 7-8. Network, loop, and radial layouts for T&D.

Radial Distribution. Most power distribution systems are designed as radial distribution systems. This layout has only one path between each customer and a substation. The electrical power flows from the substation to the customer along a single path, which, if interrupted, results in complete loss of power to the customer. Radial design is by far the most widely used form of distribution design, accounting for over ninety-nine percent of all distribution construction in North America. Its predominance is due to lower cost than the other two alternatives and simpler planning, design, and operation.

The radial system configuration provides simplicity in trouble shooting and design analysis, and predictability of performance. Because there is only one path between each customer and the substation, the direction of power flow is absolutely certain. Equally important, the load on any element of the system can be determined in the most straightforward manner — by simply adding up all customer loads “downstream” from that element. Regulators and capacitors can be sized, located, and set using relatively simple procedures because the direction of power flow is known.

Radial feeder systems are less reliable than loop or network systems because there is only one path between the substation and the customer. Thus, if any element along this path fails, a loss of power delivery results. When a failure occurs, a repair crew may be

dispatched to temporarily re-switch the radial pattern network, transferring the interrupted customers onto another feeder, if this option is available, until the damaged element can be repaired. This is possible because many radial feeder systems are built as networks, but operated as a radial by opening switches at certain points throughout the physical network. The planner determines the layout of the network and the size of each feeder segment in that network and decides where the open points should be for best operation as a set of radial feeders. This practice minimizes the period of outage.

Figure 7-9 illustrates two different ways to approach the layout of a radial distribution system. One uses multiple parallel branches and the other a large main trunk. Each has advantages and disadvantages with respect to the other in certain situations, but neither is superior in terms of reliability, cost, protection, and service quality. Most planning engineers have a preference for one or the other, and there is a lot of variety and significantly different ways to layout a distribution system. It should be noted that major differences in design standards exist among electric utilities. Therefore, comparison of statistics or practice from one to the other may not be valid.

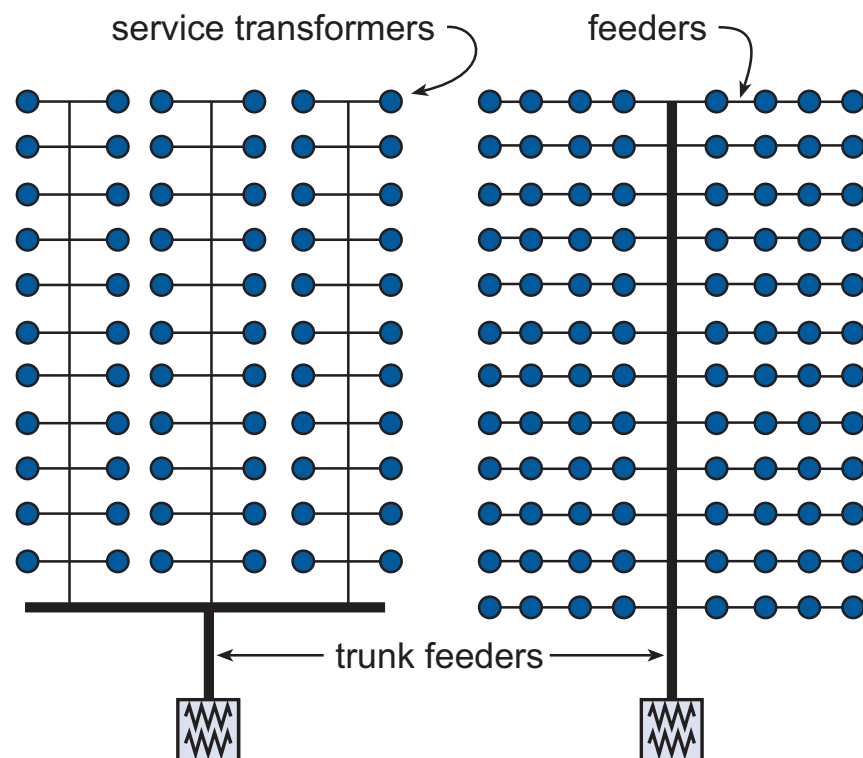

Figure 7-9. Parallel branches and main trunk layouts of distribution.

Loop Distribution. A distribution loop system provides two paths between the power sources (substation and service transformers) and every customer. Equipment is sized and each loop is designed so that service can be maintained regardless of where an open point might be on the loop. Because of this requirement, whether operated radially (with one open point in each loop) or with closed loops, the basic requirements for equipment capacity of the loop feeder design do not change.

In terms of complexity, a loop feeder system is only slightly more complicated than a radial system—power usually flows out from both sides toward the middle, and in all cases can take only one of two routes. Voltage drop, sizing, and protection engineering are only slightly more complicated than for radial systems. The loop system with relay-operated breakers and sectionalizers is more reliable than radial systems. When part of the line is down, service will not be interrupted to the majority of customers because there is no “downstream” portion.

In this example, distribution feeders carry power away from the urban substation to customers in the vicinity, 2 to 4 miles. In a densely populated area, the system may physically be built like an overhead network. However, open switches make the system operate electrically radially. Loops are generally not closed unless there is an overload or voltage regulation problem. The distribution is designed to operate radial and loop operation is normally monitored.

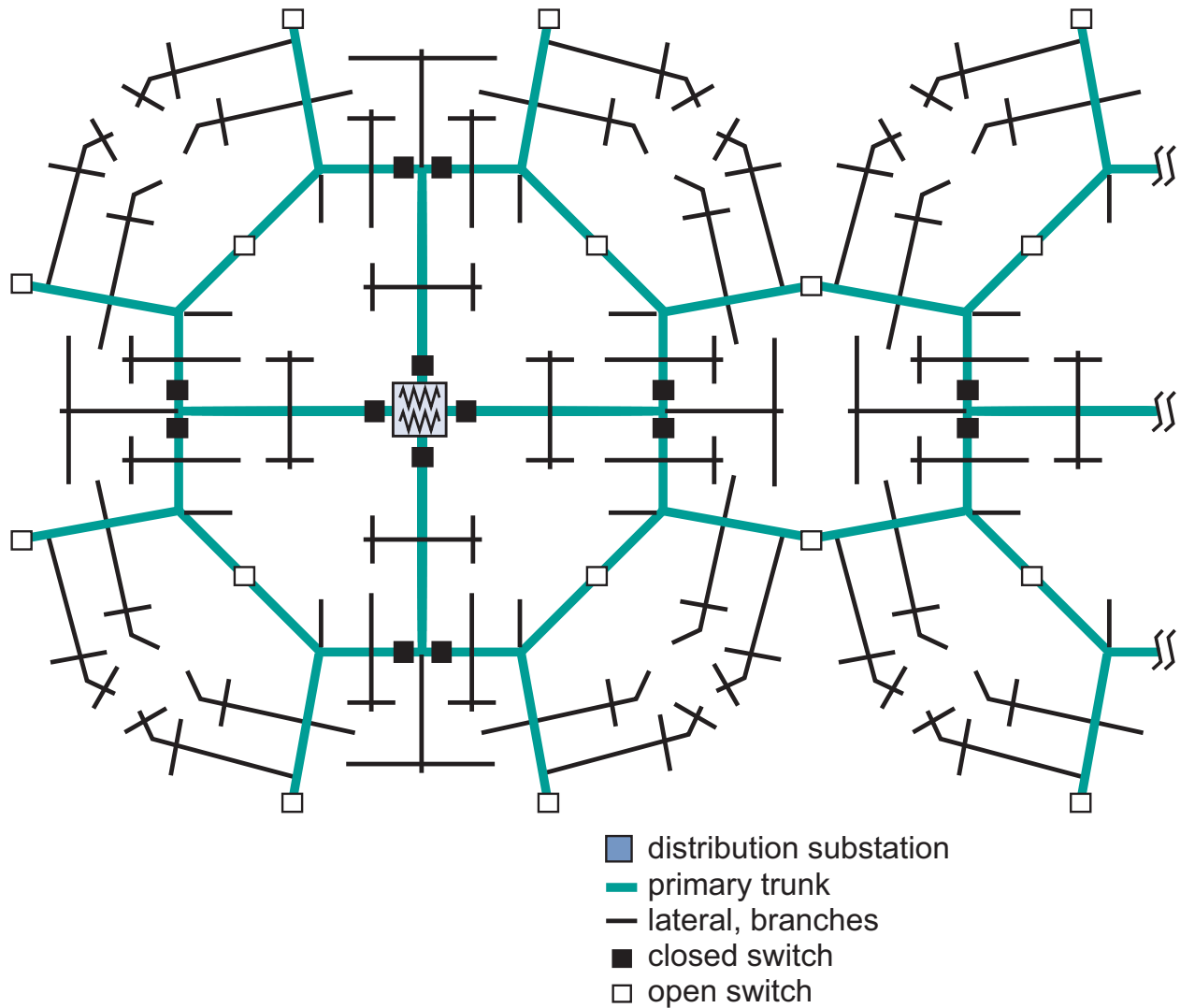

Figure 7-10. Radial-operated distribution feeders often look like a network.

The major disadvantage of loop systems is capacity and cost. A loop must be able to meet all power and voltage drop requirements when fed from either end, not both. It needs extra capacity on each end, and the conductor must be large enough to handle the power and voltage drop needs of the entire feeder if fed from either end. So the loop system is inherently more reliable but more costly than a radial system.

Networked Distribution. Distribution networks are the most complicated but most reliable of the distribution options. A network involves multiple paths between all points in the network. Power flow between any two points is usually split among several paths, and if a failure occurs, the network instantly and automatically finds

another path. So a distribution network almost always involves interlaced radial feeders and a network secondary system—a grid of electrically strong connectors (that is, connectors larger than needed to feed customers in the immediate area) that connect all the customers together at utilization voltage. The interlaced configuration means that alternate service transformers along any street or circuit path are fed from alternate feeders, as shown in Figure 7-11.

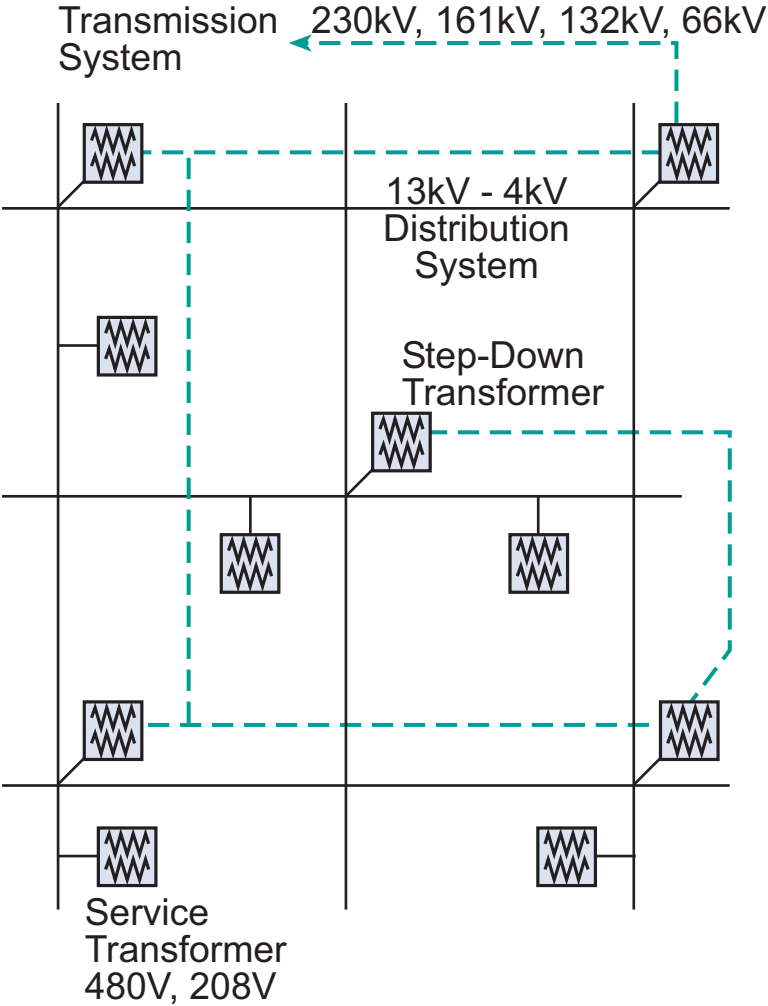

Figure 7-11. Interlaced configuration of typical networked distribution.

Most distribution networks are underground because they are employed only in high-density areas, where overhead space is not available. In the densely populated regions, such as the center of a large metropolitan area, networks are not inherently more

expensive than radial systems designed to serve the same loads. Such concentrated load densities require a very large number of circuits and underground construction anyway.

Networks do have one major disadvantage: They are much more complicated than other forms of distribution, and thus much more difficult to analyze. There is no simple “downstream” side, so the load seen by any unit of equipment cannot be obtained by merely adding up customers on one side of it. Also, the direction of power flow through the network cannot be assumed. Load and power flow, fault calculations, and protection must be determined by network techniques such as those used by transmission planners.

7.C.7 Established Policy Objectives and DG

The California Legislature set policy objectives to help guide deregulation decisions. These established policy objectives set for the restructured electric services industry in California aim to provide electric services that are safe, reliable, high quality, with minimal environmental impact, and at reasonable prices. This section addresses each one of these objectives with and without DG and intends to describe how objective may be met in the future. Table 7-3 provides a summary of other support documents.

Table 7-3. Codes, standards, and other agencies supporting policy objectives.

<i>Objectives – How to Assess</i>	<i>Safety</i>	<i>Reliability</i>	<i>High Quality</i>	<i>Environment Impact</i>	<i>Reasonable Cost</i>
<i>T&D</i>	NESC	NERC	ANSI	EPA	ORA, FERC
<i>T&D interface with Generation</i>	NESC, IEEE Stds Interface	NERC, IEEE 1366,	ANSI, IEC, IEEE PES	EPA	ORA, FERC
<i>T&D interface with End-use Consumption</i>	NESC, IEEE Stds, NEC	NERC, IEEE 1366,	IEC, IEEE IAS	EPA	ORA, FERC
<p><u>Key</u></p> <p>NESC – National Electric Safety Code</p> <p>NEC – National Electric Code</p> <p>NERC – North American Electric Reliability Council</p> <p>ORA – Office of Rate Payer Advocates of California Public Utility's Commission</p> <p>FERC – Federal Energy Regulatory Commission</p> <p>IEEE IAS – IEEE Industrial Applications Society</p> <p>IEEE PES – IEEE Power Engineering Society</p> <p>EPA - Environmental Protection Agency</p>					

a) Adequate Safety with Deregulation

In the transition from the traditional vertically integrated utility industry to a deregulated T&D, no changes have occurred in safety expectation or requirements.

These requirements are detailed in the National Electric Safety Code (NESC), which is an approved ANSI/IEEE standard. The most recent edition is dated 1997. This standard covers basic provisions for safeguarding of persons from hazards arising from the installation, operation, or maintenance of:

- conductors and equipment in electric supply stations, and
- overhead and underground electric supply and communication lines.

It also includes work rules for the construction, maintenance, and operation of electric supply and communication lines and equipment. The standard is applicable to the

systems and equipment operated by utilities, or similar systems and equipment, of an industrial establishment or complex under the control of qualified persons.

Most utilities have their own established safety procedures for de-energized electric transmission and distribution work. While the specific rules used by other utilities may differ, each set of rules contain eight basic steps: (1) request for work, (2) identification of work area and development of switching sequence, (3) de-energize work area - opening of switches, tagging, and testing for potential in work area, (5) grounding and installation of protective barriers, (6) performance of maintenance or repair work, (7) removal of grounds and barriers, and (8) restoration of service. Individual wires companies working with the IEEE NESC[®] will evaluate and define safety requirements in a deregulated electric industry.

Background on NESC. Work on the NESC[®] started in 1913 at the National Bureau of Standards (NBS). The Institute of Electrical and Electronics Engineers, Inc., was designated as the administrative secretariat for ANSI C2 in January 1973, assuming the functions formerly performed by the National Bureau of Standards. These rules contain the basic provisions that are considered necessary for the safety of employees and the public under the specified conditions. They are updated as required to address safety concern or evolving industry practices. For example, in the current edition the definition of generating station was updated, work rules were amended for tagging equipment when SCADA is used, and a requirement for overcurrent protection of power transformers was added. Even so, this code is not intended as a design specification or as an instruction manual.

Currently these rules cover supply and communication lines, equipment, and associated work practices employed by a public or private electric supply, communications, railway, or similar utility in the exercise of its function as a utility. They cover similar systems under the control of qualified persons, such as those associated with an industrial complex or utility interactive system. NESC[®] rules do not cover installations in mines, ships, railway rolling equipment, aircraft, or automotive equipment, or utilization wiring except as covered in Parts 1 and 3. For building utilization wiring requirements, see the National Electrical Code (NEC[®]), NFPA 70-1999. When DG

begins to play a larger role in the operation of the power system, no doubt that the NESC[®] will respond as necessary to maintain safety.

Safety and T&D with DG. The interconnection of DG facilities on distribution feeders introduces additional safety concerns for utility personnel responsible for the maintenance of these feeders. These concerns are likely to dictate that additional steps be added to the work procedures for feeders known to or suspected of supplying DG facilities. Table 7-4 shows a typical set of work procedures for de-energizing and re-energizing.

Table 7-4. Typical work procedures for de-energizing and reenergizing transmission, distribution, and DG systems (from IEEE Std 1001-1989).

<i>Steps</i>	<i>Description</i>
1. Prepare work request	A work request is submitted by utility's line crew to the system operator in charge of the part of the system in which work is to be performed.
2. Identify work area and write switching instructions	The line crew identifies the electric lines and/or equipment that needs to be deenergized. The system operator prepares a written description of the required switching and tagging operations that will be used to direct the line crews.
3. Notify DG owners	The system operator or a service representative will inform the owner/operator of any DG connected in the work area, of date and time work is to be performed, and the approximate duration of the outage.
4. Deenergize work area	The line crew(s), under the direction of the system operator: (a) opens, locks, and tags all disconnect switches associated with DG installations to prevent inadvertent energization of the work area. (b) Performs the required switching and tagging identified in step 2, which will deenergize the electric lines and/or equipment in the work area.
5. Confirm deenergization	No switch, jumper or fused cutout can be closed unless authorized by the permit holder. The line crew checks all electrical conductors and equipment in the work area for potential. If the checks indicate the circuit is still energized, then the system operator and the line crew must determine the source and disconnect it before proceeding.
6. Notify line crew of work clearance	After confirming deenergization, the line crew permit holder(s) notifies each line crew or lineman that the electric lines in the work areas are deenergized.
7. Install protective grounds	All grounding connections must be installed first at the grounding point, then they are connected to the electrical equipment or electric lines that are to be grounded. The DG installations shall be treated as sources and a ground connection established. This ground shall preferably be located directly on the output conductors between the utility and generator where the proper location is visually identifiable without reference to drawings.
8. Erect protective barriers	Barriers or guards must be erected on any energized facilities within a prescribed distance to provide for the safety of the line crew(s).
9. Perform maintenance work	Once the electric lines and equipment are deenergized, tagged, tested for potential, grounded, and barriers erected, work by the line crews can be performed.
10. Remove barriers and grounds	After work is completed, the barriers and grounds are removed in reverse order of their installation.
11. Notify operator of clearance to energize	Each permit holder gives written or verbal clearance to the system operator to reenergize the section of the electric system in which work was performed.
12. Remove tags and restore utility service	The line crew removes the tags and closes each switch, fuse or jumper and reenergizes the section of the electric system in which work was performed.
13. Restore DG service	Utility line crews unlock all DG disconnect switches and inform each DG operator that it is safe to resume parallel operation with the utility system.
14. Written record by system operator	The system operator maintains a written record of all switching operations, including the time each operation was performed.

Steps 1-2, 4(b)-12 and 14 are the minimum procedures for electric system maintenance; steps 3, 4(a) and 13 are the additional steps required for maintenance on electrical systems with DG devices present.

Should such work procedures be adopted, several specific actions would be required. First, the precise identification of all DG facilities would have to be determined. This is especially important for emergency conditions, such as periods of severe storm damage, where emergency crews from other utilities are used to help restore service. A manual disconnect switch would likely be required by the utility for all power sources connected to the electric system near the work area. It would have to be visible and lockable in the open position. This requirement is currently in the IEEE 1547 draft interconnection standard.

Prior to the interconnection of the DG to the electric system, the utility personnel would inspect the relays, switchgear, arresters, and other interconnection hardware at the utility/DG interface to ensure that this equipment provides adequate protection and safety. Identifying, isolating, and tagging the DG can be time-consuming, especially where there are a number of facilities in the work area. It may be more economical to use live-line maintenance procedures on these feeders, even though live-line work typically requires more time than de-energized work and is performed by specially trained personnel. It also may be safer in the long run.

Modifications may have to be made to the automatic reclosing devices to assure that out-of-phase reclosures cannot occur. This applies not only to the DG generators but also to rotating equipment of other feeder customers that may be kept energized and rotating until the DG generators are disconnected. A problem can exist if the DG is a synchronous generator or if the feeder capacitance values are such that self-excitation of an induction generator DG can occur. While the DG owner is responsible to evaluate the effect on his own generation and provide suitable protection, the utility will be required to provide protection for other users on the feeder if such a condition can occur.

Utilities sometimes use circuit breakers and sometimes reclosers for primary feeder protection and switching at the substation. Reclosers are usually used out on the feeders where (0 - 15 sec - 30 sec) and (0 - 5 sec - 15 sec) reclosing time intervals are typical settings used on both. The "0" is actually 20 cycles for the circuit breakers and 1½ seconds for the reclosers. Based on the relay settings mentioned above, it seems

reasonable that all the DG will be disconnected, and the other feeder loads de-energized before the 1½ second reclosure of the recloser. For the very fast 20-cycle circuit breaker reclosing time, it is doubtful whether all the feeder loads would be de-energized. A danger of out-of-phase reclosing therefore exists.

There are two possible solutions. One solution is to use voltage supervision of all reclosing; that is, don't allow the device to reclose if voltage exists on the downstream side of the device. While this is possible for circuit breakers and relay-controllable shunt-trip reclosers, it is not possible for most of the series-trip reclosers. But these reclosers already have the 1½ second reclosing time (which is acceptable), so they do not need the voltage supervision.

Because the series trip reclosers are satisfactory, it appears that a simpler solution to the circuit breaker problem is to increase its initial reclosing interval from 20 cycles to the 1½ seconds of the recloser. If this were done, they would not have to use the voltage supervision.

b) High Reliability

Reliability as it relates to the delivery of power from generation to load is a measure of the availability of power to the consumers. The principle determinants of reliability of a power system are factors that relate to frequency and duration of service interruptions. Many system and customer or load indices have been used to quantify reliability. The IEEE working group on system design, IEEE P1366, is currently working on standardized definition of these reliability indices. The following indices have been published in the IEEE 1366, "Trial Use Guide for Electric Power Distribution Reliability Indices."

c) Reliability Indices

IEEE 1366 has defined reliability indices. These indices will be used to measure the reliability of the delivery of power from generation to load. With the deregulation of generation and transfer of many operational and reliability functions to the ISO, such indices are bound to receive more interest and use. In particular the likelihood of new distributed generation has caused a lot of debate on how indices will be impacted. The following are the technical definitions currently adopted:

SAIFI: System average interruption frequency index (sustained interruptions).

The system average interruption frequency index is designed to give information about the average frequency of sustained interruptions per customer over a predefined area. In words, the definition is:

$$\text{SAIFI} = \frac{\text{Total Number of Customer Interruptions}}{\text{Total Number of Customers Served}}$$

SAIDI: System average interruption duration index. This index is commonly referred to as Customer Minutes of Interruption or Customer Hours, and is designed to provide information about the average time the customers are interrupted. In words, the definition is:

$$\text{SAIDI} = \frac{\sum \text{Customer Interruption Durations}}{\text{Total Number of Customers Served}}$$

CAIDI: Customer average interruption duration index. CAIDI represents the average time required to restore service to the average customer per sustained interruption. In words, the definition is:

$$\text{CAIDI} = \frac{\sum \text{Customer Interruption Durations}}{\text{Total Number of Customers Interruptions}}$$

ASAI: Average service availability index. The average service availability index represents the fraction of time (often in percentage) that a customer has power provided during one year or the defined reporting period. In words, the definition is:

$$\text{ASAI} = \frac{\text{Customer Hours Service Availability}}{\text{Customer Hours Service Demand}}$$

d) Reliability Index Survey

The Working Group on System Design has conducted two surveys on distribution reliability index usage. The first one was completed in 1990, and the second was completed in 1995. The purpose of the surveys was to determine index usage. In 1990, 100 U.S. utilities were surveyed, 49 of which responded. In 1995, 209 utilities were surveyed, 64 of which responded.

Both surveys showed that the most commonly used indices are SAIFI, SAIDI, CAIDI, and ASAI. The results of the survey along with values of these indices as reported by utilities are presented in a working group paper “A Nationwide Survey of Distribution Reliability Measurement Practices” by IEEE/PES Working Group on System Design, Paper No.98 WM 218.

Loss of generation and inability to transport power from generation to load are the two principal factors that would affect the reliability of power as delivered to the consumer. Loss of generation accounts for a small portion of outages. A survey conducted by City of Austin Utilities in 1995 shows that approximately 85 to 90% of the outages are due to problems on the traditional distribution system, which is mainly the portion of the circuit that extends from the utility substation to the customer’s service equipment. While this percent may vary from utility to utility, records of any California utility should show the same approximate breakdown of outages assigned to either loss of generation, transmission, or distribution.

The reason for this breakdown can be easily understood by reviewing the main causes for outages: weather-related events such as lightning, sleet, and ice storms; animal and tree contact; car-pole accidents; and equipment failure.

e) Reliability Events

Definitions of several categories of interruptions as defined by IEEE Trial Use Standard 1366 are provided in the glossary. These include “interruption” and six subcategories of interruptions.

f) Reliability and T&D with DG

The issue at hand is to determine how existing reliability of the power system may be impacted because of the interaction of the new decentralized generation with the T&D infrastructure and how this is any different from the interaction of central-station generators with the T&D system or with end-use loads with the T&D system. The answer to the question depends on the framework in which decentralized generation is connected to the grid. Also, the reliability at a particular end user with DG may be different from the neighbor. Therefore, reliability with DG and system reliability both need to be evaluated.

g) Reliability Enhanced at End-User with DG

A simple reliability calculation shows that adding generation at the end user improves reliability. The challenge here is how to measure “customer” reliability instead of “system” reliability, because what matters to the customer is how continuity of service to his premises ultimately equates to process interruptions, lost revenue, or some kind of other measurable loss. To illustrate this, the availability of power as measured at the customer is shown in Figure 7-12, with and without on-site DG. Notice that even with switchable generators, the percent availability of power to the customer increases by the presence of DG.

A. Parallel Supply: Customer Supplied by Generator and Utility Feeder

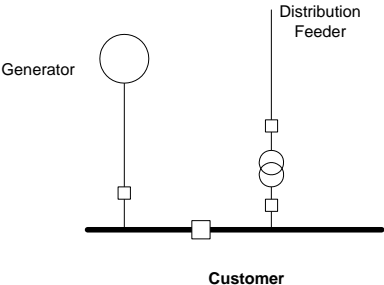
		Feeder	Generator
	Failures per year	3	8
	Restoration/Repair time per failure	4	30 hours repair time per failure
	Availability:	99.86%	97.26%
	Total Availability: 99.9962%		

B. Parallel Supply: Customer Supplied by either Utility Feeder or Generator with A transfer Switch

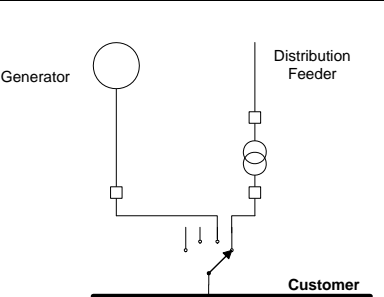
		Feeder	Generator
	Failures per year	3	8
	Restoration/Repair time per failure	4	30 hours repair time per failure
	Availability:	99.86%	97.26%
	Transfer Time: ½ Hour		
Total Availability: 99.978%			

C. Parallel Supply: Two Generators

	Failures per year for Each	8
	Restoration/Repair time per failure	30 hours repair time per failure
	Availability:	97.26%
	Total Availability: 99.883% (<u>Unavailability hours for the two parallel units is 6.7, compared to 30 for one unit. As the number of units in parallel increase, this number goes down. For 3 units in parallel it is less than 20 minutes</u>)	

Figure 7-12. Reliability of end-use consumer with DG.

h) Reliability Concerns for Distribution Feeder with DG

Technically, there is no reason why decentralized generation cannot be seamlessly integrated with the distribution system without affecting reliability. Under the existing environment in which distribution protection and reliability schemes are mostly designed with a radial distribution feed and cascaded power flow in one direction in mind, the interaction of the new generation with the distribution system is going to negatively impact the reliability of the system unless each situation is carefully evaluated before installing the distributed generation. It does not have to be this way because of any fundamental technical reason—the only reason is that distribution systems are not designed for handling two-way power flow from the beginning, which is entirely different from the transmission network, which has been designed with the premise that power flow can be bi-directional.

For example, many utilities use automatic sectionalizers to isolate faulted sections of distribution circuits. By doing so, reliability of the system is increased because the duration and the number of customers losing power is significantly reduced by reconfiguration of the system and serving the customer from an alternate circuit.

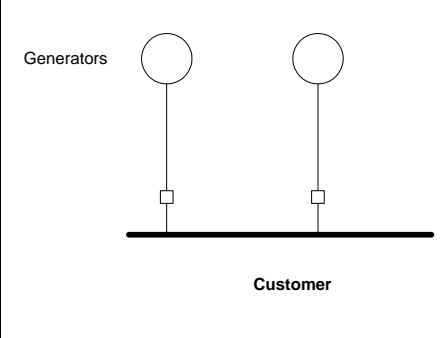
Both three-phase and single-phase units are available and are used for three-phase feeder applications and single-phase lateral applications respectively. Automatic sectionalizers do not have sufficient interrupting capacity to clear fault currents (they can interrupt load currents) and are used in conjunction with a suitable upstream

interrupting device such as a circuit breaker. Automatic sectionalizers work by detecting the presence of a fault current downstream of their location. When such current is detected, they wait for a circuit breaker upstream of their location to de-energize the line. Once this occurs, the sectionalizer contacts open. When the upstream breaker recloses, the faulted section of line will have been removed from the circuit.

Sectionalizers can be programmed to allow the upstream breaker to attempt repeated reclosures prior to the opening of the sectionalizer contacts. DG units placed downstream of the sectionalizer may interfere with its operation by keeping the line energized longer than would ordinarily be the case with the utility source alone. Large DG units located downstream of the sectionalizer but feeding faults upstream of its location may also confuse the sectionalizer logic so that it thinks the faulted section of the line is downstream of its location.

While ownership of the DG has no bearing on how it will impact the reliability of the system, seamless integration of the unit will require close cooperation between the integrator of the DG unit and the distribution system operator who has designed the coordination and protection schemes without considering the existence of decentralized generation. It is very possible that protection schemes and in some cases protective equipment on the distribution grid will have to be modified in order to accommodate the installation of a generating unit in the system.

Technically, there is no reason why decentralized generation cannot be seamlessly integrated with the distribution system without affecting reliability. However, somebody has to decide who pays for the cost of the system study that may be required and also distribution protection-scheme changes that may have to be implemented for a seamless integration.

Studies such as these are routine for connecting central generators to the transmission grid. However, due to the economies of scale, the cost of such a study as compared to the generator cost is minimal. Unfortunately, in the case of decentralized generation, while the complexity of the analysis is reduced because of the unique radial design of distribution system and its protection scheme, the cost of the analysis and distribution

system reconfiguration (if required) becomes an increasing portion of the total generator cost.

When distribution automation is available, it may play a key role in minimizing the risk of DG negatively impacting the distribution system. Many potential problems arising from dispersed resources on electric distribution feeders stem from the common practice of operating distribution feeders “open loop”; that is, operating with little central communication between the utility and the load. Many problems, such as islanding, are diminished when the communication loop between the utility system and the dispersed resource is closed. Distribution automation is a tool for closing that loop. The higher the speed of the communications system, the tighter the loop becomes.

i) Reliability and T&D with End-Use Consumption

Concern over misoperation of distribution system protection schemes is by no means unique to decentralized generation. Large synchronous motors used in many process industries could cause the same response on the sectionlizer by feeding upstream faults. However, when distribution systems are designed for new loads, fault contribution from end-use loads, if they are significant, are taken into account during the design stage. There is no technical fundamental reason why it cannot be done for distributed generation as well. But the main issue is: once the system has been designed in a certain way taking into account the interaction of the end-use load, the addition of decentralized generation on a new large synchronous motor load to that system will require a reevaluation of the original design scheme in order to ensure that proper coordination is possible with the DG unit.

End-use consumption can have a beneficial impact on system reliability as well. When the load is able and allowed to participate as a resource in reliability, the pool of reserves is increased. This provides the system operator with additional reliability resources. This can be especially important during times when there is a capacity shortage in the energy and ancillary service markets.

j) High Quality Power

Power quality has emerged as an important issue for end-use customers. Historically, power quality issues had been the domain of electric utilities, which focused on

reducing or eliminating power outages. However, the recent proliferation in use of electronic equipment and microprocessor-based controls has caused electric utilities to redefine power quality in terms of the quality of voltage supply rather than availability of power. In this regard, IEEE Std. 1159-1995, “Recommended Practice for Monitoring Electric Power Quality,” has defined a set of terminologies and their characteristics to describe the electrical environment in terms of voltage quality. Table 7-5 shows the categories of power quality disturbances with spectral content, typical duration, and typical magnitude.

While these definitions describe the technical characteristics of the quality of voltage and current, the ultimate definition of power quality lies in the ability of the end-use equipment to work in the normal electrical environment. Power quality has more to do with compatibility of load and electrical system rather than a set of technical descriptions that defines the boundary of what is acceptable and what is not.

Table 7-5. Categories of power quality variation – IEEE 1159-1995.

Categories	Spectral Content	Typical Duration	Typical Magnitudes
1.0 Transients			
1.1 Impulsive			
1.1.1 Voltage	> 5 kHz	< 200 μs	
1.1.2 Current	> 5 kHz	< 200 μs	
1.2 Oscillatory			
1.2.1 Low Frequency	< 500 kHz	< 30 cycles	
1.2.2 Medium Frequency	300–2 kHz	< 3 cycles	
1.2.3 High Frequency	> 2 kHz	< 0.5 cycle	
2.0 Short-Duration Variations			
2.1 Sags			
2.1.1 Instantaneous		0.5–30 cycles	0.1–1.0 pu
2.1.2 Momentary		30–120 cycles	0.1–1.0 pu
2.1.3 Temporary		2 sec–2 min	0.1–1.0 pu
2.2 Swells			
2.2.1 Instantaneous		0.5–30 cycles	0.1–1.8 pu
2.2.2 Momentary		30–120 cycles	0.1–1.8 pu
2.2.3 Temporary		2 sec–2 min	0.1–1.8 pu
3.0 Long-Duration Variations			
3.1 Overvoltages		> 2 min	0.1–1.2 pu
3.2 Undervoltages		> 2 min	0.8–1.0 pu
4.0 Interruptions			
4.1 Momentary		< 2 sec	0
4.2 Temporary		2 sec–2 min	0
4.3 Long-Term		> 2 min	0
5.0 Waveform Distortion			
5.2 Voltage	0–100th Harmonic	steady-state	0–20%
5.3 Current	0–100th Harmonic	steady-state	0–100%
6.0 Waveform Notching	0–200 kHz	steady-state	
7.0 Flicker	< 30 Hz	intermittent	0.1–7%
8.0 Noise	0–200 kHz	intermittent	

k) Quality Power and T&D with DG

Of the power quality disturbances listed in the table, the two main categories that are commonly referred to as a limiting factor for DG penetration are waveform distortion, also known as harmonics, and flicker. Both of these elements are mainly due to the interruptions of end-use loads with the T&D system. Distributed resources depending on the technology applied may also affect these elements. However, this impact is no different than that of the interaction between end-use loads and the T&D system and can be treated the same way as end-use loads.

One of the principal issues in power quality-related constraint that is often talked about is the harmonic current injected by DG equipment using static converters and its impact on waveform distortion. However, implementation of guidelines and standards for harmonic current emission for DG devices (similar to what has been done for end-use loads through application of IEEE 519-1992 “IEEE Recommended Practices and Requirements for Harmonic Control in Electrical Power Systems”) will ensure that generation and loads have the possibility of negatively impacting the grid voltage waveform distortion.

Another power quality category that is often cited as a limiting factor for some types of new generation, especially wind and PV, is flicker. Flicker results directly from the interaction of T&D with time-varying generators and loads. Arc furnaces, welders, and motor starting have been primary the cause of flicker in the T&D system. Traditionally, the GE flicker curve, which defines the objectionable range of irritation based on the frequency and magnitude of voltage variation, has been used in order to ensure that flicker-producing loads are not connected to the T&D system without using mitigation methods (see Figure 7-13). However, the difficulty in quantifying flicker using the curve has led to the development of a new method, which quantifies the severity of flicker and provides recommended guidelines for connection of possible flicker-producing loads.

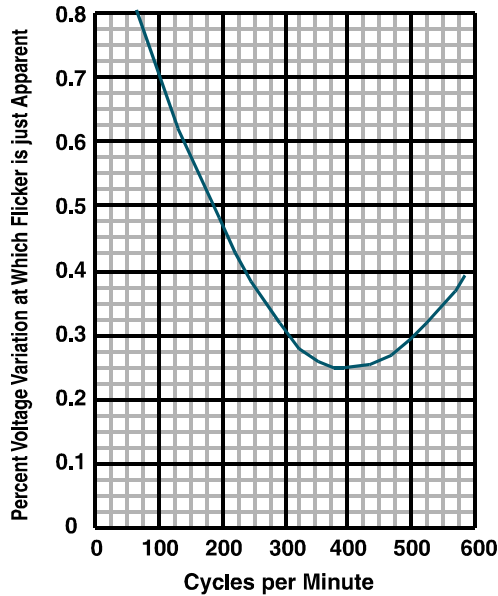

Figure 7-13. Original flicker curve by Willard Brown, GE, 1921.

More recently, efforts of the International Union of Electro-Heat (UIE) in Europe led the combining of flicker Standards from France, England, Germany, and Japan to a new international standard on flicker measurement, IEC 1000-4-15 (formerly IEC 868). The UIE flicker measuring method is based on a comprehensive sophisticated simulation of the lamp-eye-brain performance, taking into account all technical details of lamp behavior and all physiological aspects of the human visual sensation system.

Monitoring with a UIE flicker meter provides a single number describing the severity of voltage fluctuations, in units of Pst (“st” referring to a short term of 10 minutes). Pst=1 is the threshold for complaints for all frequencies. A longer-term severity measurement uses the Plt scale (“lt” refers to a longer term of two hours). Pst_M is the maximum over the measurement period. The severity level can be obtained at different probability levels to filter out rare events. For example, the measurement of Pst_{t99%} is the value having a probability of 1% to be exceeded during a significant measurement period, and Pst_{95%} has a 5% probability.

Current activities in IEEE P1547 are geared towards defining the standard of interconnection for new generation using the same methodology that is used to connect loads to the T&D system. Implementation of this standard will ensure that interaction of

new generation with a T&D system in producing objectionable flicker will be treated the same way as is done for loads without affecting the quality of the supply to other customers.

The current debate on both harmonics and flicker is related to whether generation should be treated differently from loads in order to minimize their interaction with the T&D system. From a fundamental point of view, generation and load should not be treated differently when it comes to either harmonic emission limits or flicker.

However, because of existing limits that were designed based on equal apportion of emission criteria to offending loads, there is no room to accommodate the generation portion of these emissions because traditional central-station generators were not a contributor to either harmonics or flicker. If generation and loads have to be treated the same way, then the limits previously designed for end-use loads need to be tightened in order to accommodate the generation portion of the emission limit, or stricter limits have to be imposed on generation.

Table 7-6. Characteristics of three-phase transformer connections use for DG applications.

Type of Distribution System	Transformer Connection Used	Advantages	Disadvantages
Four-wire multigrounded neutral	grounded-wye high-side/delta low-side	<ul style="list-style-type: none"> Prevents high-side overvoltages during faults (acts as a ground source) Good for power converters that can't be grounded Provides isolation for power converters from utility system voltage swells 	<ul style="list-style-type: none"> Zero sequence circulating currents in delta winding (grounding impedance required on wye side to limit this) This winding arrangement would not usually be available as the existing transformer at most customer sites Desensitizes feeder ground fault protection by acting as a ground source
	grounded-wye high-side/grounded-wye low-side	<ul style="list-style-type: none"> Prevents high-side overvoltages during faults (only if generator is effectively grounded) Prevents zero sequence circulating current on low side Commonly available as the existing transformer configuration at customer sites 	<ul style="list-style-type: none"> The generator itself must be effectively grounded if this type of transformer bank is to act as an effectively grounded source (this is sometimes not possible)
	delta high-side /grounded-wye low-side	<ul style="list-style-type: none"> Sometimes available as the existing transformer configuration at customer sites 	<ul style="list-style-type: none"> Larger units above 100 kVA pose the very real threat of causing damaging overvoltages during utility ground faults

Type of Distribution System	Transformer Connection Used	Advantages	Disadvantages
			<ul style="list-style-type: none"> • Could cause ferroresonance during single phase operation
	delta high-side/delta low-side	<ul style="list-style-type: none"> • Provides best isolation of voltage swells and sags reaching the power converter • Good for power converters that can't be grounded 	<ul style="list-style-type: none"> • Larger units above 100 kVA pose the very real threat of causing damaging overvoltages during utility ground faults or islanded operation
Three-wire ungrounded system	delta high-side/delta low-side	<ul style="list-style-type: none"> • Should provide good performance 	<ul style="list-style-type: none"> • No ground reference makes ground fault detection more difficult
	delta high-side /grounded-wye low-side	<ul style="list-style-type: none"> • Should provide good performance • Provides a ground reference on the generator side 	<ul style="list-style-type: none"> • Unbalanced output on generator could create zero sequence circulation on delta high-side winding.

l) Quality Power and T&D with End-Use Consumption

Most of the power quality categories as described in IEEE 1159-1995 are characterized by typical duration, which ranges from microseconds to seconds. These short-duration disturbances, resulting from either faults in the electrical system or a consequence of normal switching operations, are expected in any electrical environment. The degree to which end-use equipment can withstand these disturbances depends to a large extent on the built-in immunity of the end-use loads to these disturbances.

Specifying the quality of voltage required is meaningless if a corresponding specification of what end-use equipment can tolerate is not specified. Unfortunately, there is no governing standard that defines the immunity of equipment. Worldwide standards regarding equipment immunity are slow to emerge due to the wide range of equipment used in the end-use sector. What has emerged in the interim is a plethora of power conditioning equipment, which the end-use customer can pick from if needed for providing the quality of power that is required by his particular load.

m) Minimal Environmental Impact

Electric power generation can be a major contributor to environmental problems. The impact of the existing industry, and of any change in industry structure, must be considered in light of overall societal interests. Environmental concerns associated with electric power generation and consumption include:

- air quality
- water quality
- noise impacts
- land use and visual impacts
- hazardous wastes
- impacts on endangered species

Air quality management districts have established limits for certain air emissions that affect human health and the environment. Regulations are based on performance standards established by the U.S. Environmental Protection Agency (EPA); however, individual jurisdictions can impose more restrictive limits. Regulations for emission limits can vary based on the type of fuel, the prime mover technology, and the size of the generating source. Among the regulated emissions are oxides of nitrogen (NO_x), carbon monoxide (CO), volatile organic compounds (VOC), sulfur oxides (SO_x) and particulate matter (PM10 and PM2.5). Most of these pollutants have been categorized as “criteria” pollutants by the EPA and are regulated as part of the National Ambient Air Quality Standards.

Carbon dioxide (CO₂) is not currently regulated; however, its identification as a greenhouse gas possibly involved in global climate change has caused considerable debate concerning its abatement.

n) Emission Control Technologies

Emission control can be categorized as either a combustion modification or a post-combustion treatment. In the former category, the rate of combustion is controlled to prevent formation of a particular pollutant. These technologies often allow combustion to occur in stages, controlling the amount of air to each stage of combustion with or without a catalyst.

In the latter category, the task is to remove the pollutant that has already been created during the combustion process. In the case of boilers using residual oil and coal, the high sulfur content requires removal of SO₂ from the flue gas, unlike natural gas, which

has a very low sulfur content. Heavy and residual oils, coal, and diesel fuel generate significant amounts of particulates that must be removed from the exhaust gas with filters or electrostatic precipitators.

Emission-control technologies were developed primarily during the 1980s in response to environmental legislation. Two post-combustion treatment technologies, selective catalytic reduction and non-selective catalytic combustion, have been successfully applied.

The most likely environmental issues for central generating plants are listed in table 7-7. Being central and large can result in high concentrations of these environmental insults. More resources can be dedicated to monitoring each emissions source, however. Smokestacks, for example, can be monitored continuously. Failures of pollution-control equipment can be detected and fixed quickly. Similarly, more money can be spent on advanced pollution-control equipment. The plants can more easily accommodate interactive control technologies that react to current environmental conditions, such as fuel switching.

Table 7-7. Environmental issues for central power generation.

<i>Environmental Issue</i>	<i>Description / Review Objectives</i>
Air Quality	Stack emissions comply with standards; controls are appropriate.
Biological Resources	No adverse impacts to surrounding ecosystem.
Hazardous Waste	Wastes are properly handled, stored, transported, and disposed.
Visual Impacts	Aesthetic evaluation of project's impact on existing landscape.
Land Use	Compatibility of project with existing/future land uses.
Solid Waste	Management and minimization of solid wastes.
Public Health	No adverse exposure of pollutants to workers and communities.
Hazardous Materials	Materials are handled and stored properly.
Water Quality/Discharge	No adverse impacts to water supply by water discharge.
Noise Impacts	Evaluation of noise audibility to workers and communities.
Soil Resources	Affects of wind- or water-induced erosion.
Accidental Releases	Release of hazardous materials to the atmosphere and local impacts.

Similarly, the large size, high cost, and long planning process associated with central generating stations accommodate environmental impact studies for each facility. The permitting process can be tailored to the specific conditions of each site.

Large facilities can more easily participate in market-based environmental solutions, such as the SO₂ allowance market. This can help minimize the cost of achieving desired environmental goals.

The transmission and distribution system does not itself contribute to air or water emissions. Power lines are considered by many to be unsightly. Substation sound from transformers is sometimes a concern in quite residential neighborhoods. Those concerns, coupled with concerns over EMF effects, often make siting transmission and distribution facilities difficult.

Transmission and distribution can impact on power plant dispatch and cost. Insufficient transmission or distribution capacity can result in dirtier generators running more often than they might otherwise run if there were sufficient transmission and distribution to bring cleaner power to market. The opposite can be true as well, however. Transmission can help dirty, remote power get to market and offset cleaner, local power if the dirty power is cheaper than the clean power.

Transmission and distribution facilitate market choice among generators. This enables green power markets, allowing market forces to reduce the environmental impact of electricity production if that is what consumers want.

o) Environment and T&D with DG

Distributed generators are often fueled with natural gas and may inherently have lower emissions than the average emissions from the central generators they are displacing. They are closer to the load, which reduces losses and can make them more responsive to individual customers needs—both of which can reduce emissions by increasing efficiency. The greatest efficiency improvement can come from the ability of distributed generation to provide cogeneration of heat, cooling, process steam, and other energy products.

The most likely environmental concerns for distributed generators are listed in Table 7-8. Being closer to the load that the generation is serving may mean that the distributed generator is closer to other residences or locations that are sensitive to noise or the visual impact. This presents a disadvantage to distributed generation.

The smaller size and lower cost of individual units can make it more difficult to monitor emissions as closely as would be done for a central generator. It may also take longer to detect faulty emission-control equipment. The administrative cost of dealing with environmental regulations must be spread over fewer MWH of energy, making it relatively more expensive. The need for “pre-qualifying” equipment is greater for distributed generation than for central plants.

Not all distributed generators are inherently low-emission units. It can be hard for reciprocating-engine-driven generators designed for emergency use to obtain air quality permits to allow continuous operation.

Distributed generators may be small enough, individually, to receive more lenient treatment for environmental emissions. This may become a concern as the total distributed generation installed capacity rises.

The transmission and distribution system still increases options for reducing generator emissions. Emissions limits can be imposed without curtailing load; other cleaner (typically more expensive) generation can replace the offending generation. Emissions allowance trading can be conducted to economically reduce emissions, although this is more difficult with small generators.

Table 7-8. Likely environmental issues for distributed generation.

■ Air Quality	■ Hazardous Materials/Waste Management
■ Emission Reduction Credits/Trading	■ Noise Impacts
■ Accidental Releases	■ Water Quality Discharge
■ Public Health	

p) Environment and T&D with End-Use Consumption

When transmission and distribution is used to enable end-use participation in real-time energy and ancillary service markets, peak emissions can be reduced. Alternatively,

loads could respond to adverse environmental conditions either through direct appeal or by monitoring the emissions.

q) Reasonable Cost

Transmission and distribution facilitate moving generation from a regulated industry to a market-based industry. Hopefully this will provide better economic efficiency for energy and ancillary (reliability) services.

Transmission costs only about one tenth as much as generation, distribution about another tenth. Direct costs can be controlled, as they historically have been, through careful regulation of the monopoly service. Cost control has to be balanced with reductions in reliability (and the resulting cost to consumers) or the reduction in commercial freedom for generators and loads (with economic consequences to both). Transmission and distribution also reduce generation costs by enabling reserve sharing. Transmission and distribution constraints are detrimental to generation markets. It is appealing to recommend building enough transmission so that it never constrains generation markets. Unfortunately, the construction of new transmission lines is often opposed by local residents and landowners and is therefore politically difficult to achieve. Regulatory rules may not permit utilities to recover fully the costs of such “overbuilt” systems. Most importantly, transmission systems that appear to be robust and flexible are designed to service a specific set of expected generation and load patterns. Attempting to facilitate all possible combinations of generation and load would overwhelm any realistic transmission system.

r) Economy and T&D with DG

Distributed generation can also be market based, providing customer choice.

Transmission and distribution facilitate customer choice and enable distributed generation to operate in the most economic manner. Cogeneration can be deployed with distributed generation, greatly increasing efficiency.

Economic efficiency is best served if distributed generators are free to enter and leave the energy and ancillary service markets when real-time prices rise above the distributed generator’s operating cost. This will dictate how many hours each distributed generator operates.

Distributed generation also provides an economic alternative to enhancing the transmission and distribution system. The size of distributed generation additions also better matches the increments of load growth, avoiding the problem of unused capacity when central generation additions are made.

s) Economy and T&D with End-use Consumption

When transmission and distribution are used to enable end-use participation in real-time energy and ancillary service markets, customers can respond to conditions on the power system. Demand elasticity is enabled. A market without demand elasticity is only half a market. Transmission and distribution reduces costs by enabling physical load aggregation, which reduces total peak demand and required generating capacity. It also greatly reduces the regulation requirement.

t) Clarification of Loop Flows

Loop flows (also known as unscheduled power flows, circulating power flows, and parallel path flows) are unintentional flows of electrical power on transmission lines between interconnected systems. The magnitude of the loop flow is related to the electrical system topology, and is a function of the different impedances of the different paths, as well as the different node voltages and phase angles.

Loop flows explain the difference between the scheduled and actual power flow, assuming zero inadvertent interchange, on a given transmission path. For example, referring to 7-14, if area X and Y agree on a certain exchange of power on a certain transmission corridor, this may not be possible due to either exchanges between X and Y or even loop flow between areas A and B over some parts of X or Y.

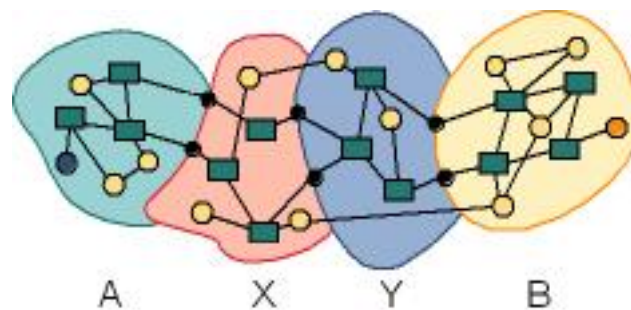

Figure 7-14. Loop flows

Loop flows are one of the reasons for congestion certain transmission lines and corridors. They also effect and hinder trades between different systems (pools) in a large interconnected network. Currently there is no consensus on a common transmission pricing methodology and, usually, each independent system operator (ISO) uses its own. This makes it difficult to calculate the cost of a transaction between two different systems especially if they are not physical neighbors—a well known problem of loop flows.

7.D Analysis of Distributed Generation Impacts On Distribution (witness B. Kirby)

7.D.1 Overview

The operation of electric power systems is fundamentally different from other utilities.

Electric systems have two unique physical characteristics:

- Electric energy is not commercially stored⁷ like natural gas and water. Production and consumption (generation and load) must be balanced in near real-time. This requires metering, computing, telecommunications, and control equipment to monitor loads, generation, and the voltages and flows throughout the power system, and to adjust generation output to match consumption.
- The transmission and distribution network is primarily passive, with few “control valves” or “booster pumps” to regulate electrical flows on individual lines. Flow-control actions are limited primarily to adjusting generation output and to opening and closing switches to add, remove, or reroute transmission and distribution lines and equipment from service.

These two operating constraints led to four reliability consequences with practical implications that dominate power system design and operations:

⁷ Electricity is not “stored” directly. When electricity is “stored,” it is converted to another form of energy and re-converted later. Pumped storage hydro converts electricity to mechanical potential energy by lifting water. Batteries convert electric energy to chemical potential energy. The re-conversion to electricity uses conventional generators or inverters.

1. Every action can potentially affect all other activities on the power system. Therefore, the operations of all bulk-power participants must be coordinated.
2. Cascading problems that quickly escalate in severity are a real threat. Failure of a single element can, if not managed properly, cause the subsequent rapid failure of many additional elements, potentially disrupting the entire power system.
3. The need to be ready for the next contingency, more than the current conditions, is factored into operations, and the likely flow that would occur if another element fails limits allowable power transfers.
4. Because electricity flows at nearly the speed of light, maintaining system stability and reliability often requires that actions be taken instantaneously (within fractions of a second), which requires automatic computations, communications, and controls.

These concepts have important consequences for what constitutes congestion and how DG interacts with the power system.

a) T&D Reliability Benefit

Because electricity cannot be stored and because generators are not perfectly reliable, it is beneficial to have additional generating capacity available, ready to respond immediately if a generator fails unexpectedly. Simultaneous failure of multiple generators is unlikely, so a single extra generator can provide reliability reserves for multiple generators if a T&D system is available to move power from the reserve generator to the place it is needed.⁸ In practice, “extra” generators are not typically used to provide the primary reliability reserve. Instead, reserve capacity is made available on many generators. Still, the role of T&D in facilitating reliability is the same.

b) T&D Economic Benefit

Transmission and distribution systems contribute to reducing operating costs as well as increasing reliability. With large numbers of generators and loads connected together, it is possible to operate the most economic mix of generation needed to serve the changing load at any given time. This is made possible by networking and providing for

⁸ Different types of reliability reserves are discussed more fully as Ancillary Services later.

dynamic power transfer from generation sources to end-use consumption points as required to maintain system energy balance.

The most economic mix of generation can be selected through traditional centralized least-cost economic dispatch (as was done historically) or through market-based competition (as is done in California today). In either case, the ability to adjust the mix of generation to economically accommodate different load patterns is facilitated by the transmission network.

c) T&D Load Diversity Benefit

Aggregating loads through the T&D system also has benefits. Individually, loads tend to fluctuate dramatically. Short-term fluctuations (faster than 10 minutes), for example, tend to be random among loads. By interconnecting many loads together, the T&D system presents a net load to the generators that is much less erratic and therefore easier (and cheaper) to follow. For example, 100 homes aggregated together present only 10 times the regulation burden that one home presents.

d) T&D and Generation

While T&D and generation, especially distributed generation (DG), can often be interchanged to provide reliability or adequacy of supply, this raises a multitude of complicated regulatory and market issues. Adding reliability-must-run generation does not facilitate energy markets and does not provide a fully adequate T&D system. On a small scale, as the load on a substation transformer grows and nears the transformer capacity, either the T&D system can be enhanced (replace the transformer with a larger unit, for example), or DG can be deployed. Similarly, on a larger scale, when the load within a region exceeds the capacity of the transmission system to access remote generation, either the transmission system can be enhanced or local generation can be installed. The need for additional capacity can be for reliability reasons (a radial line is simply inadequate to carry the required load) or for economic reasons (the load would like to access cheaper remote generation sources). Usually it is for a combination of the two, and differentiating between them is difficult.

7.D.2 Technical Attributes of End-use Consumption

The following technical attributes are typically used to distinguish or classify end-use consumption. They describe the electrical characteristics of consumer equipment that may impact the functions of end-use consumption in a power system. Not listed as attributes are generic types or named technologies of load equipment such as induction motor, nonlinear electronic device, electromagnet ballast, and linear heating element. These named technologies are often used to classify end-use load equipment but they are not measures of performance or specific technical attributes. Traditional load characteristics of end-use consumption include:

a) Voltage Level

Voltage at the electric service entrance or at the point of common coupling with the EPS. For a consumer, this is usually the low-side voltage of the service transformer. For specific loads or appliances, it is normally the terminal voltage where the appliance (cord-connected or hard-wired) interfaces with the building wiring system. Standard voltage levels are given in ANSI C 84.1 and are measured in volts per phase or as the average of three phases.

b) Peak Demand

Typically the maximum of a 15- or 30-minute average energy consumption. Often measured when the power system sets its peak demand (coincident peak). This is measured in MW or kW.

c) Energy Consumption

Amount of energy consumed over the billing period. This is measured in MWH or kWh. The ratio of the energy consumed (over a year, for example) to power capacity is the load factor.

d) Regulation Requirement

The burden the load places on the power system due to the minute-to-minute fluctuations in real-power requirements. Regulation requirements can be measured as the standard deviation of the two-minute energy consumption requirements measured over an hour. Regulation requirements vary among customers. Aggregation greatly reduces the regulation requirement for the entire system.

e) Impedance

Electrical nature of the load device may be primarily resistive, capacitive, or inductive. These characteristics can be directly measured and are given in ohms at 60 Hz, or in frequency-independent Ohms, Farads, and Henries. Electronic equipment has the special characteristic of a nonlinear or varying impedance. Practices for measuring the impedance of nonlinear electronic equipment have not been established except with respect to harmonic distortion measures.

f) Energizing and Inrush Current

Peak current usually measured as a multiplier or percent of full-rated RMS current. Also called starting current, inrush current can be as high as three to eight times the normal starting current for such loads as induction motors starting from the locked-rotor position. It is measured in amps based on a short-term RMS reading (not instantaneous, but ½ to one cycle RMS measurement).

g) Diversity and Duty Cycle

Indicates the degree that many independent end-use loads are operating at the same time, including variations in the levels for the same appliance. The aggregate load is expected to have a level of diversity defined as the difference between the sum of the maxima of two or more individual loads and the coincident of combined maximum load, usually measured over a specified period. This measurement can be in kVA, kW, or amps.

h) Power Factor

The ratio of the real power consumed to the apparent power. This is a measure of the reactive power requirement of the load. Additional definitions of distortion power factor and true power factor may be applicable when measuring power quality problems.

i) Dynamic Response

The load response when changes occur in the voltage or frequency of the power system. Most load equipment have a predictable response, which is measured as constant impedance (resistive lighting), constant power (motors, computers), or constant $V \times I$.

j) Current Distortion

The degree to which equipment generates a nonlinear relationship between the applied voltage and the current drawn. This distortion is measured in percent total harmonic distortion (THD), individual harmonic (HD) or total distortion (TD). During measurement, the test voltage source must be regulated, have a standard known impedance, and have a sinusoidal voltage waveform.

7.D.3 End-use Consumption and DG

Individual loads present different challenges to the power system. Often these challenges are at least partially under the control of the load, either through changes in the real-time operation or in the design of the load. These differences are accentuated when DG is present because the number of possible operating modes is increased. In a restructured environment, additional characteristics should be of concern:

a) Real-Time Energy Consumption or Production

The value of energy changes in real time, as can be seen from wholesale market behavior. Loads and distributed generators should see real-time energy prices so that end users and DG owners have the option to modify the behavior of their equipment to help the power system and reduce their costs.

b) Individual Ancillary Service Consumption or Production

Loads vary dramatically in their ancillary service consumption. Loads that use less of an ancillary service (for example, the relatively low regulation burden of an aluminum smelter) should not be charged average rates that subsidize the heavy ancillary service users (for example, the relatively high regulation burden of an arc furnace mill). Figure 7-15 shows two loads with similar energy requirements that have dramatically different ancillary service requirements. Loads and distributed generators that can provide ancillary services to the power system should be allowed to do so. As with energy, the value varies in real-time. Prices should vary in real-time as well.

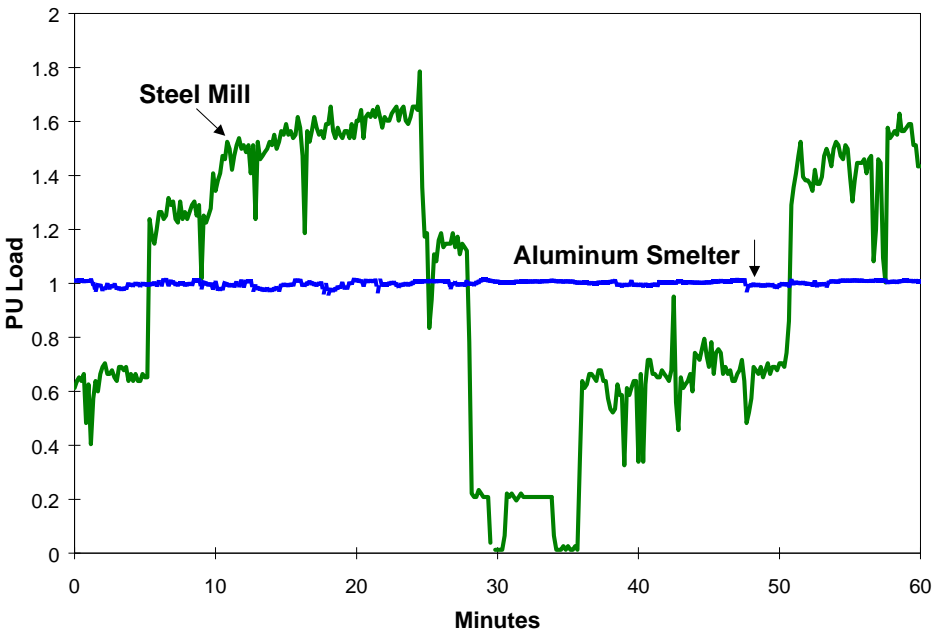

Figure 7-15. Individual loads impose different ancillary service requirements.

c) Location.

The value of energy changes with location on the power system if there is congestion present. Loads and distributed generators should see the locational price signals to enable them to participate in relieving congestion.

7.D.4 Technical Attributes of Generation

The following technical attributes are typically used to distinguish and classify generation. They describe generator electrical characteristics that may impact the functions of generation in a power system. None of these attributes depend on ownership of generation, including the ownership of DG. They may affect operational aspects of the generation functions, but they do not depend on them. Not listed are the different generic types or named generator technologies such as induction, synchronous, and inverter. These generic names are often used to classify generators but are not measures of performance or specific technical attributes.

a) Voltage Level

Voltage at the electric service entrance or at the point of common coupling with the EPS. Generation voltage level is measured in volts per phase or given as the average of three phases. Standard voltage levels are given in ANSI C 84.1. Note that the variation of the three phases may also be of interest. This variation is measured as a percent of unbalance, which is the largest voltage of two phases divided by the average of the three.

b) Power Capacity

Ability to deliver real power to the power system. This is measured in MW or kW.

c) Energy Capacity

Ability to deliver power over a length of time (energy is the time integral of power). This characteristic is measured in MWH or kWH. The ratio of the energy capability (over a year, for example) to power capacity is the capacity factor.

d) Efficiency

The ratio of the electric energy generated to the primary energy supplied. The primary losses usually occur in the thermal cycle for conversion from heat to mechanical energy. Here it is important to consider whether the waste heat is (or can be) used. Additional losses occur in the electric generator for conversion from mechanical to electric energy.

e) Short-Circuit (SC) kVA

Internal characteristics of the generator or the combination of generator and step-up transformer determine the short-circuit kVA. The SC power given in MVA or kVA is usually calculated based on these factors, rather than measured. Generation has a transient and a sub-transient response characteristic. Therefore, two different values may be given. Also, SC kVA may be measured as a “contribution” ratio, defined in the IEEE draft standard 1547 as the aggregated DG SC kVA divided by the system SCt kVA.

f) Ramp Rate

Ability to change power output, measured in MW/min. This is also often taken as a measure of controllability because there currently is no good controllability metric.

g) Dispatchability

Ability to switch between the non-operating and the operating states (and visa-versa) and to deliver a specified real-power output upon command. Metrics include minimum on-time, minimum off-time, and minimum startup time.

h) Reliability

The total amount of time the generator is forced out of service and the number of times per year are important metrics for reliability.

i) Reactive Power and Voltage Support

The ability to produce reactive power and control the local power system voltage is a valuable characteristic. This is measured in terms of the total reactive capability (MVAR) or in terms of the power factor that the generator can support at full output.

j) Voltage Quality

Voltage needs to be suitable for interconnection with the public power supply or for serving local load equipment. Voltage quality is the dominant quality issue when the generator is operated as a voltage source (impedance of the generator is relatively low and I_{SC} relatively high compared to the power system at the point of common coupling). It is measured by the output voltage regulation (percent of rated), waveform (percent V_{THD}), and frequency (percent of rated).

k) Current Quality

Current needs to be suitable for interconnection with the public power supply or for serving local load equipment. Current quality is the dominant quality issue when the generator is operated as a current source (impedance of the generator is relatively high and I_{SC} relatively low compared to the power system at the point of common coupling). It is measured by the output current regulation (fluctuations per unit time or flicker rate) and waveform (percent I_{THD}).

l) Comparison of Central Plant and Distributed Generation Attributes

DG and central-station generation share many of the same attributes, they are both generation components. Both convert energy from some other form to electricity and inject it into the power system. There are a range of technologies in both distributed and central generation that exhibit a range of capabilities and limitations. Some of each are

dispatchable, for example, and some are not. Distributed photovoltaic systems can be switched on or off but they are not dispatchable in the sense that a central fossil plant can be run up and down to follow load. Central nuclear plants do not follow load either and are essentially not dispatchable. Distributed diesel generators can be run up and down to follow load.

The cost comparison is a first order issue. Generation plant production cost depend on many factors including: capital cost, fuel cost, operating cost, efficiency and cogeneration opportunities. Which cost dominates varies depending primarily on the technology employed but dominant costs tend to be fuel, capital and environmental mitigation. Marketing costs are dominated by T&D costs including system operations, customer service and capital costs. A major difference between central and distributed generation plants may be production costs compared to marketing costs. Before deregulation the cost to market central station power was imbedded in the other rates. Production costs were generally low because of large scale and proximity to low-cost fuel sources. Since DG is located at or near the market with smaller scale and further from low-cost fuels, marketing costs are expected to be relatively lower than production costs for DG. These cost comparisons should be made now that generation is unbundled and all costs should be tracked separately.

The fundamental difference between distributed generation and central generation is that DG is relatively dispersed among the loads while central generation is relatively concentrated at specific locations remote from loads. Distributed generators range in size from a few hundred watts for a small photovoltaic generator to 10 MW for a combustion turbine. Typically distributed generators are a few tens of KW to a few hundred KW. Central-station generators range in size from about 10 MW to 1300 MW. The size demarcation is only approximate. Though most central station generators are larger than 10 MW some units, especially some older hydro units, are smaller.

Size is important, however. The ISO may not be willing to deal with resources that are smaller than some minimum size (10 MW). Using a collection of smaller distributed generators to provide a resource that is large enough to be useful will require aggregation. This function could be provided by the owner of multiple distributed

generators, by a third party, by a distribution provider, or by a branch of the ISO itself if it chose to do so.

Central stations are typically manned while distributed generators are typically unmanned but this is not universally true. Many hydro and combustion turbine generators are unmanned. *DG facilities* are often manned.

There are a number of secondary characteristics that often, though not always, distinguish distributed generators from central stations:

- Observability and controllability require metering and communications to allow the system operator to monitor each generator. Large central stations can afford the equipment required to facilitate monitoring every few seconds. This is a greater economic burden for distributed generators.
- The sudden loss of a large central station is a serious reliability concern for the power system. Since it is unlikely that numerous distributed generators will fail simultaneously they do not pose the same reliability concern.
- An aggregation of distributed generators will often have a higher ramp rate than an equivalently sized central generating station since response is spread over numerous units. This can be an advantage in supplying ancillary services.

7.D.5 Disaggregate California Generation

California's 53 GW of generating capacity comes from a diverse mix of nearly 1000 plants. As shown in Table 7-9, the basic energy comes from fossil fuels, renewable resources (including conversion of waste to energy), and nuclear power. Plant size, measured by electric power capacity, spans five orders of magnitude, with the largest being 127,000 times the size of the smallest. The greatest size diversity occurs within the hydroelectric plants, with the smallest having only 0.02 MW of capacity and the largest having 1495 MW. The Plants fired by oil and natural gas span a similar range.

Table 7-9. California has a diverse mix of generating plants.

<i>Fuel Type</i>	<i># Plants</i>	<i>Maximum MW</i>	<i>Minimum MW</i>	<i>Average MW</i>	<i>Total MW</i>
Coal	16	97	17.0	35	562
Geothermal	45	124	0.70	55	2466
Hydroelectric	388	1495	0.02	36	13892
Nuclear	2	2160	2150	2155	4310
Oil / Natural Gas	341	2083	0.10	87	29529
Solar	14	80	0.13	29	413
Wind	99	110	0.20	17	1724
Waste to Energy	92	55	0.10	10	951
Total	997	2160	0.02	54	53847

Several of the fuel types can be further subdivided. Solar plants, for example, subdivide into photovoltaic systems that utilize solar cells to generate electricity directly from the sun and solar thermal plants that use sunlight to generate steam that turns a turbine to produce electricity. The photovoltaic plants are smaller than the solar thermal plants, with the former ranging in size from 0.1 to 2 MW and the latter ranging from 30 to 80 MW.

The size of the nearly 30 GW of plants fueled by oil and gas (55% of the generating capacity in California and over 1/3 of the plants) tends to be tied to the generating technology. The largest plants are steam turbines, combustion turbines, and combined cycle plants. Mid-sized plants are combustion turbines, combined cycle, and cogeneration facilities, including some combined-cycle internal-combustion-engine plants. Reciprocating engines dominate in the smaller size plants.

Hydroelectric plants can be separated into a number of categories including conventional plants, run-of-river plants, and pressure reducing stations. The former tend to be larger while the latter tend to be small.

The waste-to-energy plants can be subdivided as well into biomass, municipal solid waste (MSW) digester gas, MSW industrial waste, MSW landfill gas, and other MSW plants. The size range within the waste-to-energy plants is not specifically tied to the type of plant. Similarly, coal plants all use steam to turn turbines but boiler technologies differ. Also, some are cogeneration facilities while some are not. Size and technology are not tightly linked for coal plants. Wind plants span a range of sizes, primarily because the number of units within each plant varies. The two nuclear plants are nearly identical in size.

Overall, a quarter of the plants are smaller than 1 MW, and half of the plants are smaller than 10 MW. However, less than 0.2% of the total system capacity currently comes from plants smaller than 1 MW, and less than 3% comes from plants smaller than 10 MW, as shown in Figure 7-16.

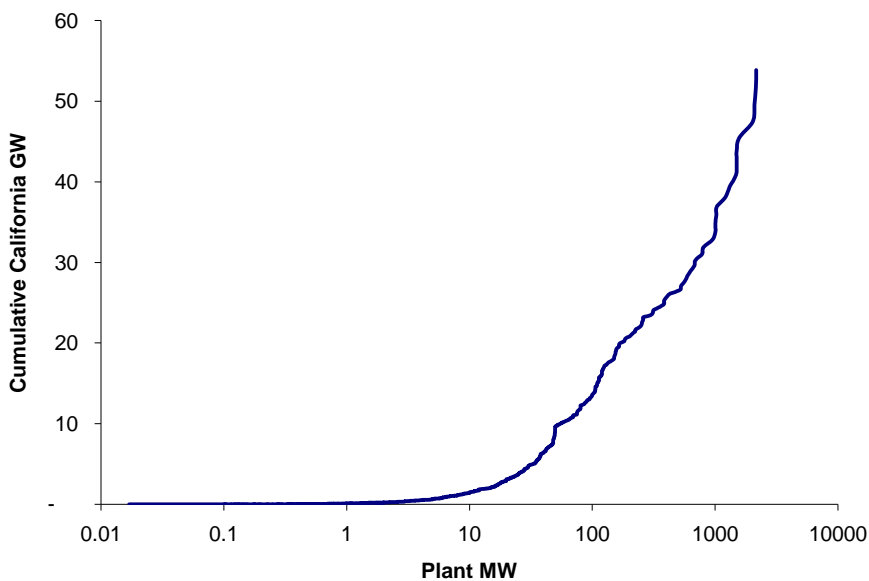

Figure 7-16. Plants larger than 10 MW dominate California's generating capacity.

7.D.6 Ancillary Services within the T&D

FERC defined ancillary services as those “necessary to support the transmission of electric power from seller to purchaser given the obligations of control areas and transmitting utilities within those control areas to maintain reliable operations of the interconnected transmission system.” This statement recognizes the importance of ancillary services for bulk-power reliability and to support commercial transactions. Though the resources

necessary to create these services are generators, and may in the future be end-use consumption, the services themselves must be deployed and controlled by the same system operator that controls the transmission system.

Ancillary services are conceptually well defined. They have existed throughout the history of the power system. However, the details of obtaining them from markets are still evolving. The following is a breakdown of ancillary services as they are currently defined in California.

a) System Control

The requirement to maintain the real-time balance between generation and load, coupled with the inability to independently control flows on individual transmission lines, results in the need for a system control function. The system operator deploys and controls the remaining ancillary services to facilitate the goal of maintaining reliability and facilitating commerce.

The operator of the transmission system facilitates the real-time balance between generation and load through the control of various ancillary services. One of these services (regulation) facilitates this balancing under normal operating conditions. Three other services (spinning reserve, non-spinning reserve, and replacement reserve) facilitate this balancing in the aftermath of system disturbances that lead to abnormal operating conditions.

The California ISO has had difficulty settling on a precise specification for the ancillary services, especially regulation. Market rules and reporting changed twice in 1999. The year started with regulation defined as a single commodity with a single price. All ancillary services were purchased in the day-ahead market in four zones. Hour-ahead markets were added to the day-ahead markets in June. “Upward” regulation was also separated from “downward” regulation in June. The price for both regulation services was the same, but a generator could restrict its offer to movement above or below its operating point.

Self-provision of ancillary services is an option that is sometimes exercised by power producers. Beginning in June of 1999, a scheduling coordinator could provide the ISO with ancillary service resources instead of paying the ISO for ancillary services.

In August, separate prices were established for upward and downward regulation and the number of zones was increased from four to 23. The “rational buyer” was also instituted in August, allowing the ISO to substitute a higher-quality ancillary service (like regulation) for a lower-quality ancillary service (like non-spinning reserve) if the former was available at a lower price than the latter.

b) Regulation

The power system operator needs rapid, automatic control over some generation resources to compensate for normal short-term fluctuations in the aggregated load and generation:

“The ISO needs sufficient Generating Units immediately responsive to Automatic Generation Control (AGC) in order to allow the ISO Control Area to meet the WSCC and NERC control performance criteria by continuously balancing Generation to meet deviations between actual and scheduled Demand and to maintain interchange schedules.”⁹

The power system operator could eliminate the need for regulation by insisting that all end-use consumption conform precisely (minute-by-minute) to its power purchase schedule. Alternatively, each end-use consumer could be required to contract with a generator to precisely match its individual minute-to-minute fluctuations. This is both impractical and wasteful.

It is impractical because many end-use consumers are incapable of controlling their loads so precisely. The communications and control requirements for compensating each load’s fluctuations would also be impractical to implement. Not aggregating is wasteful because it significantly increases the total regulation requirement and the cost to serve the load. The random nature of the end user’s loads results in an aggregated fluctuation that is typically much lower than the sum of the individual fluctuations. For example, the relative fluctuations of 100 homes individually is 10 times higher than 100 homes collectively.

⁹ California Independent System Operator Corporation, FERC Electric Tariff, Original Volume III, Ancillary Services Requirements Protocol, Sheet No. 611, Effective September 1, 1998.

Much less generating capacity needs to be dedicated to compensate for load fluctuations when loads are aggregated. Consequently, it is appropriate for the power system operator to provide this service to the collection of generators and loads. That is not to say that individuals should not be assessed for their specific individual contributions to the system's regulation requirement, only that the assessment would be less when the service is provided to an aggregation than when the service is provided to loads individually.

c) Operating Reserve

The power system must always be prepared to survive the unexpected loss of a generator or a transmission line. To accomplish this, the power system operator is required to maintain contingency reserves:

“The ISO needs, as a minimum, Operating Reserves, consisting of Spinning Reserve and Non-Spinning Reserve, sufficient to meet WSCC MORC. The Operating Reserve requirement shall be equal to (a) 5% of Demand (except the Demand covered by firm purchases from outside the ISO Control Area) to be met by Generation from hydroelectric resources, plus 7% of the Demand (except the Demand covered by firm purchases from outside the ISO Control Area) to be met by Generation from other resources, or (b) the single largest Contingency, if this is greater or (c) by reference to such more stringent criteria as the ISO may determine from time to time.”¹⁰

d) Spinning Operating Reserve

At least half the operating reserve must be spinning reserve:

“Each Generating Unit or external import of a System Resource scheduled to provide Spinning Reserve must be capable of converting the full capacity reserved to Energy production within ten minutes after the issue of the Dispatch instruction by the ISO, and of maintaining that output or scheduled interchange for at least two hours. . . .”

Spinning reserve units are also required to be “responsive to frequency deviations.”¹¹

¹⁰ California Independent System Operator Corporation, FERC Electric Tariff, Original Volume III, Ancillary Services Requirements Protocol, Sheet No. 613-614, Effective February 9, 1999.

¹¹ California Independent System Operator Corporation, FERC Electric Tariff, Original Volume III, Ancillary Services Requirements Protocol, Sheet No. 613-614, Effective July 27, 1998.

e) Non-Spinning Operating Reserve

The definition of non-spinning reserve is similar to that of spinning reserve except that the reserve is not required to be frequency responsive. In addition, non-spinning reserve does not have to be provided by generation; it can be provided by dispatchable demand, interruptible exports, certified off-line generation, or external imports.

f) Replacement Reserve

Operating reserves must be restored so that the system is prepared for a subsequent unexpected outage. The ISO accomplishes this by procuring replacement reserves. Replacement reserves must be capable of responding within one hour and sustaining that response for an additional two hours. They can be generators, loads, or resources from outside the ISO's control area.

Together, spinning reserve, non-spinning reserve, and replacement reserve provide resources that begin responding immediately to an unexpected event, are fully deployed within ten minutes, are capable of responding to a second event within one hour, and can sustain the total response for three hours. This coordinated set of resources is designed to provide sufficient time for markets to begin functioning again and return the system to normal operations. All of these services and regulations are procured through day-ahead and hour-ahead markets run by the ISO.

Figure 7-17 provides a summary of deployment times for various ancillary services. Reserves are deployed only during contingency operations, whereas regulation and voltage control are required during both normal and contingency operations.

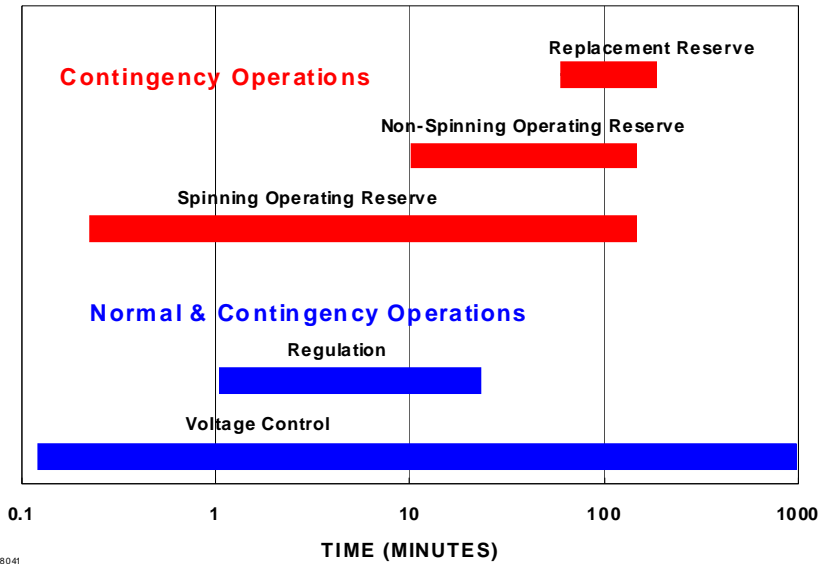

Figure 7-17. Ancillary services are distinguished by their deployment times and durations.

g) Voltage Control and Black Start

The ISO obtains two additional ancillary services from generators: voltage control and black start. Because of relatively strict geographic requirements for these two services, the ISO does not run markets for them. Instead, all generators are required to provide limited reactive support and voltage control without compensation. Reactive support, the generation or absorption of reactive power (MVAR), is the resource that is used to control the voltage in the vicinity of the generator. All generators are required to be capable of following an ISO-supplied voltage schedule under automatic voltage control within a power factor of 0.90 lag and 0.95 lead. The ISO will compensate generators if it requires them to provide additional reactive support and voltage control.

The ISO determines the system’s black start requirements needed to ensure that the *system* can be restored to service expeditiously if it should ever fail completely. The ISO enters into long-term contracts with selected black start units. Each black start unit must be capable of starting, without external assistance, within ten minutes. It must be capable of supplying the reactive power requirements and controlling the voltage of the energized transmission system. It must be capable of operating for a minimum of 12 hours.

7.D.7 Technical Attributes of T&D

The following technical attributes are typically used to distinguish or classify T&D. They describe T&D electrical characteristics that may impact the functions of T&D in a power system. None of these attributes depend on ownership. They may affect operational aspects of the T&D functions but they do not depend on them. Not included in these attributes are generic types or named technologies of T&D such as transmission level, sub-transmission level, and sub-station level. These named technologies are often used to classify T&D but are not measures of performance or specific technical attributes.

a) Voltage Level

T&D lines are characterized by the voltage level at which they normally operate.

Standard voltage levels for the U.S. are provided in ANSI C84-1. Voltage is an important characteristic of T&D. It is possible to move more power through a smaller right-of-way with lower losses and at lower capital cost if the voltage is raised.

Unfortunately, higher voltage requires better insulation, which often requires more space. It may not be practical to put sufficient insulation in equipment to accommodate the highest voltage desired. Large central-station generators, for example, are rarely designed to operate above 33 kV, even though they are often coupled to 230-kV or 500-kV transmission systems. Similarly, residential loads operate at 120 or 220 volts, commercial loads use up to 440 volts, and industrial loads use up to 4160 volts.

Transformers are used to interconnect portions of the power system that operate at different voltage levels.

b) Power Transfer Limits

The amount of power that can be transferred is measured in kW or MW at a certain power factor, or in kVA and MVA. This limit can be the direct limit of the component or can be a contingency limit based on what loading will be under specific contingency conditions. Also measured as ampacity, the current limit or thermal rating of the line or other series component, like a transformer, under normal temperature conditions. Ampacity limits can vary significantly depending on the outdoor temperature and clearances that may limit allowable line sag.

c) Line Loss

The difference between the energy that enters the T&D system and the energy that is delivered for end-use consumption. These losses are measured in kWh or MWh. While the relationship between voltage, current, capital cost, and losses is complex, it is increased current that necessitates larger, heavier conductors. Line losses typically rise with the square of the current. Current depends on network configuration and generation and load patterns. Extra energy, beyond that which is being consumed by loads, is needed from generators to compensate for the real-power losses incurred by the T&D system as it moves power from generators to loads.

d) Short-Circuit (SC) kVA at PCC

The SC power given in MVA or kVA is usually calculated rather than measured. In some cases, a ratio is useful to evaluate the relative size of a load on the T&D. A short-circuit ratio (SCR) is defined as the short-circuit power divided by the average or maximum demand power of the load (or distributed generator) being evaluated. This parameter is also referred to as “stiffness ratio.” Higher stiffness ratios are usually desirable. For example, a stiffness ratio of greater than 100 may allow a DG to be connected with fewer interconnection requirements than a system with a ratio of 20. The calculation parameters depend on line length, size, and impedance, particularly of the last upstream transformer. This calculation will determine the available short-circuit kVA. Also, any nearby spinning motors or generators can also contribute to the calculation.

e) Reactive Power Requirements

Wire type, spacing, and installation configuration determine the basic electrical characteristics of the lines. All pieces of power system equipment exhibit all three electrical characteristics (resistance, capacitance, and inductance). However, one is usually dominant. For example, long high-voltage transmission lines tend to be electrically capacitive, whereas lower-voltage distribution lines and transformers are electrically inductive. The dominant characteristic also changes with loading. Lines are capacitive when they are lightly loaded but inductive when they are heavily loaded. These electrical characteristics can impact stability and voltage regulation. They also determine transient response and interactions with other power system components. For

computation purposes, resistance is measured in ohms per conductor mile, inductive reactance in ohms per conductor mile, and shunt capacitive reactance in meg-ohms per conductor mile. These characteristics are usually given at 60 Hz.

f) Voltage Regulation and Drop

The range of voltage levels at the receiving end of the lines for different load current levels. Both real and reactive power loading affect load current. Voltage regulation is measured as a percent of nominal voltage and usually includes a range from slightly higher than nominal voltage at no load to a several percent lower for full load. Regulation becomes more critical at points of service and is less critical for bulk transmission.

g) Overload and Short-Circuit Protection

This attribute protects various elements of the T&D by acting on abnormal current conditions. Circuit breakers, fuses, and reclosers are the common devices used for this protection. The overload trip is a slower, load-break action, which is different than a short-circuit interrupting capability. All protective devices have limits on the level of current that they can interrupt, called an interruption rating. Some switches have no load-break rating and cannot be opened unless the circuit is de-energized or has no load.

h) Lightning Protection and BIL

Lightening arrestors provide a path to ground and static wires provide shielding for phase conductors exposed to lightning. T&D elements have a basic insulation level (BIL) in kV. When the voltage exceeds this BIL, a flashover can be expected. For lightning, which seeks the ground, the flashovers are usually to grounded parts of the T&D. Lightning arrestor help to hold voltage below the BIL ratings of equipment and thus prevent damaging flashovers. In some cases, a very high lightning current and high resistance in the path to ground can cause the higher points of metal towers to reach voltages that exceed the BIL between the tower and other phases. In this case, backflash occurs and often causes a power outage or disturbance for end users. For DG connected into the T&D, it will be important to make sure that the overvoltage-withstand capability of the generation and related elements is equal to or above the BIL level of the T&D. Otherwise, the DG may become a weak point in the withstand capability of

the T&D and will be vulnerable to high voltages being discharged from the T&D system to the DG, particularly those caused by lightning.

i) Grounding

The T&D system may be effectively referenced to ground, ungrounded, or grounded through a resistance, capacitance, or inductance. Grounding techniques affect circuit protection, relay and control design, flow of harmonic or stray currents, and overall performance of T&D. A key issue in the addition of generators to the T&D system is that the grounding of the generation is compatible with the grounding of the T&D system. This will be a key check point for adding DG in the T&D system.

7.D.8 Key Operations and Assets in a Restructured EPS

Transmission and distribution provides the interconnection between loads and generators. This interconnection function coupled with a system control element maintains the real-time balance of generation and load under normal and abnormal conditions. Control over the T&D system must be exercised with the objectives of facilitating energy markets and maintaining reliability. To perform this control, a system operator is appointed. The operator maintains an energy balance using real-time information from the T&D system, from generators, and from loads.

T&D facilities can be owned and maintained by other parties. However, the system operator must not have a commercial interest in the energy markets. Similarly, maintenance can be performed by a party with commercial interest, but the maintenance must be *scheduled* by the system operator. For example, approving of maintenance schedules and issuing permits for taking equipment out of service need to be controlled by the system operator, whose objective is to facilitate energy commerce and maintain reliability. If the system operator had a commercial interest in energy markets, then the operator might exercise that control authority in favor of its own interest. A system operator with commercial interest might schedule maintenance at times of high prices, when that action restricted the output of a competitor's generation, and at times of low prices, when it restricted the output of its own generation.

The historic distinction between transmission and distribution is less important. That distinction concerns who has regulatory jurisdiction over individual T&D assets. No matter

who has jurisdiction over each piece, the entire T&D system, from the points where generators inject power into the network to the points where loads remove it, must be under the control (not necessarily ownership) of entities that do not have commercial interest in the energy market and whose objective is to maintain reliability and facilitate that market.

In order to meet reliability-related key policy objectives established for the restructured electric service industry in California, the T&D function needs to provide the following key operations:

- Proper maintenance of existing infrastructure.
- Real-time monitoring and control of the T&D systems through supervisory control and data acquisition (SCADA) systems.
- System protection and fault clearing.
- T&D planning and load forecasting .
- Respond to customer trouble calls.
- Restore and repair service during system emergencies.
- Maintain the required reliability and quality of power delivered to end users.
- Host a standards department to keep up-to-date on relevant standards pertaining to engineering design, construction environmental, safety, and any other issue that will be relevant for the T&D function.

7.D.9 Congestion Constraints in a Restructured EPS

As with all generators connected to the power system, the operation of DG has to be coordinated with the operation of the rest of the system. The objectives of the system designers and operators are to ensure reliability and to accommodate commercial activity. Under many (hopefully most) conditions, the operator of each individual generator will be free to respond to market conditions at will. However, under some conditions, operations at individual generators will have to be curtailed or compelled based upon the condition of the T&D system and/or the activities of other market participants. The system operator monitors the T&D system, the generators, and the loads (at least in aggregate) in real time to ensure

reliability. The system operator also purchases and deploys ancillary services to maintain the viability of the system.

a) Definition of Congestion

Adequacy of a T&D system has two criteria: 1) The system must have enough capacity to support the balancing of load and generation, even during known and expected outages. 2) It must have enough capacity so that competitive generation markets can function. When there is a desire or need to move more power through a portion of the transmission and distribution system than the system can support, congestion results.

Transmission and distribution and local generation can be so inadequate (congested) that it is not possible to meet the load requirements in a given location, which would be a reliability concern. The system load must then be curtailed to prevent a collapse of the power system.

More commonly, when T&D and local generation are sufficient to support the load but inadequate to allow complete freedom in generation choice, the generation dispatch must be constrained, in an economically sub-optimal way, to maintain system reliability. The result is a higher price on one side of the constraint and a lower price on the other. In the extreme case, specific generators must run to maintain security. These “reliability-must-run” generators can have substantial market power. Any resource that must run for system reliability reasons could charge any price it desired in an open market, at least until alternative resources were drawn into the market. Market power also exists when the need for one generator to operate restricts the ability of another generator to participate in the market. Consequently, such generators often run at the system operator’s discretion and receive a regulated payment. This applies whether the generation is central or distributed. “Reliability-must-run,” “local peaking,” and “local generation to offset T&D investment” or “T&D deferral” all refer to local (or location-specific) generation that must be run because T&D is not adequate to fully support reliability and commerce without support from specific generators.

Flow of power within a T&D system depends on the configuration of the system, as well as the generation and load patterns within the system. There is little ability to control the flow of power within the network other than by removing elements (taking

lines out of service) or by changing the generation injections.¹² Planners test system adequacy by modeling performance (line flows and bus voltages) under a full range of expected load, generation, and contingency conditions. Limits on the acceptable generation dispatch range are determined for each set of operating conditions. The planners then make a judgment as to the adequacy of the T&D system.

In a networked system, congestion is not related to the actual flows within lines. Congestion occurs when security-constrained dispatch requires modification of the economic dispatch. This modification occurs most frequently as the result of contingency analysis rather than because of steady-state line flows. The generation dispatch is modified because a line will overload if a specific contingency occurs, such as when a generator or line trips. Because there is no time to take corrective action to prevent cascading failures, it is necessary to preemptively modify the generation dispatch. Modification of the dispatch affects access of generators to the grid, which can be an exercise of the access component of market power. It is this off-economic dispatch that results in cost differences from location to location. Losses in the T&D system also cause geographic cost differences but have a much smaller impact and are easier to deal with than congestion.

The need for enhancement is less clear in the more common case when inadequate T&D results in constraints on economic dispatch of generators rather than forcing curtailment of load.¹³ The complexity is twofold. First, the underlying increased cost of electricity that will result from constraining the dispatch is generally an operating cost whose magnitude depends on the number of hours a year the constraint exists and the relative costs of operating the generators involved. This increased cost can be the cost of paying for “reliability-must-run” generation or simply the cost of incrementing one generator and decrementing another. This applies whether the generation is central or distributed.

At the same time, the T&D enhancement cost is primarily a capital cost, which must be recovered over several decades. The operator has two choices: The operator can live

¹² Phase-angle regulators and flexible AC transmission systems (FACTS devices) provide limited, and expensive, control of flows at a few specific locations.

¹³ Controlling the pre-contingency (normal conditions) injection of power by generators can ensure that the post-contingency line flows are within emergency ratings of all lines.

with the cost of re-dispatching generators to avoid congestion or the operator can enhance the system to increase capacity. Which solution is the more economical depends on a number of factors, such as fuel costs, the cost of capital, and the expected locations and magnitudes of load growth and generation construction.

Second, because the dispatch alternatives to enhancing the T&D system result in an increase in the cost of electricity rather than curtailment of load, the need for the enhancement is less clearly tied to reliability. It may be harder to gain public acceptance for a new transmission or distribution enhancement project under these conditions than for a project that is more clearly tied exclusively to reliability.

Management of congestion through the forced dispatch of existing generation (reliability-must-run) becomes necessary where location-specific prices do not exist to clear supply and demand imbalances across congested T&D interfaces.

b) Description of Transmission Congestion

In the absence of congestion (current or anticipated) and short of operational reliability problems, there is no need to invest in T&D expansion; the existing system is adequate to reliably handle all desired transactions. In theory, such a system can allow for a minimum-cost dispatch of generation (and load reductions).

Figure 7-18, on the other hand, presents an example where the flow from Area A to Area B can become congested. A consequence of a congested interface is that it creates a bottleneck, which prohibits delivery of otherwise economic energy supplies to consumers on the high-cost side of the bottleneck. This means that these consumers pay more for their power than they would if there were sufficient capacity to carry all economic transactions. In other words, energy costs genuinely depend upon location, given T&D constraints.

When the load in Area B reaches a level where the transmission line is fully loaded (800 MW in this example) and no more power can be delivered from Area A to meet demand in Area B, then more expensive generation than would otherwise be required must be run in Area B. For example, when the transmission line is fully loaded, some customers in Area B would be forced to obtain electricity from the generator G1, which is \$6/MWh more expensive than the electricity from Area A. These costs will occur

regardless of whether individual customers see them in their bills. Although congestion is based upon reliability requirements—that is, the transmission line cannot reliably carry more than 800 MW—the consequences are economic.

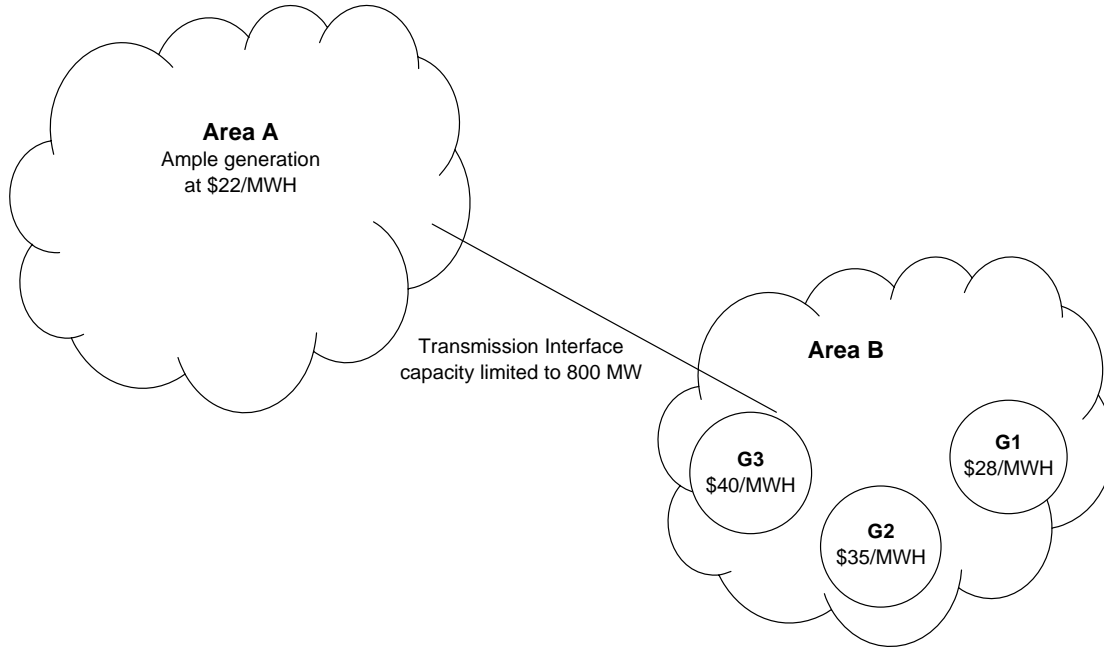

Figure 7-18. Congested transmission interface that limits power flows from Area A to Area B.

In any particular circumstance, there are usually several alternatives to relieve congestion. Effective relief methods can include installation and/or operation of large or small-scale generation for energy production in the areas negatively affected by the congestion, for voltage support, to enhance stability, or to force flows on specific lines. T&D solutions can include construction of new lines or facilities, upgrading of lines or facilities, installation of voltage support (capacitors, reactors, tap changers, synchronous condensers, or static VAR compensators), installation of flow-control devices (phase-angle regulators or FACTS devices), and power system stabilizers at generating stations. These technologies allow more power to be delivered over a line or to operate the system more reliably.

Figure 7-19 shows a situation where one of two parallel paths loads to capacity before the other does, leaving 250 MW of line capacity unavailable to support power transfers. Accepting the line limit and allowing the more expensive generation market in Area B

to operate may be the best solution if the congestion is infrequent, does not last long, or the price differential between areas A and B is not great. Alternatively, a FACTS device or phase-angle regulator could be used to block the flow on the limiting line, allowing additional power to flow on the line with remaining capacity. Running a specific unit (generator G3 in this case, located at the delivery end of the congested line) that is out of economic order may reduce flows on the limiting line sufficiently to allow additional energy to be imported over the parallel path. Similarly, controlling demand, either throughout Area B or specifically near the termination of the limiting line, can relieve congestion. In all cases, an investment is required to reduce the cost of service in Area B.

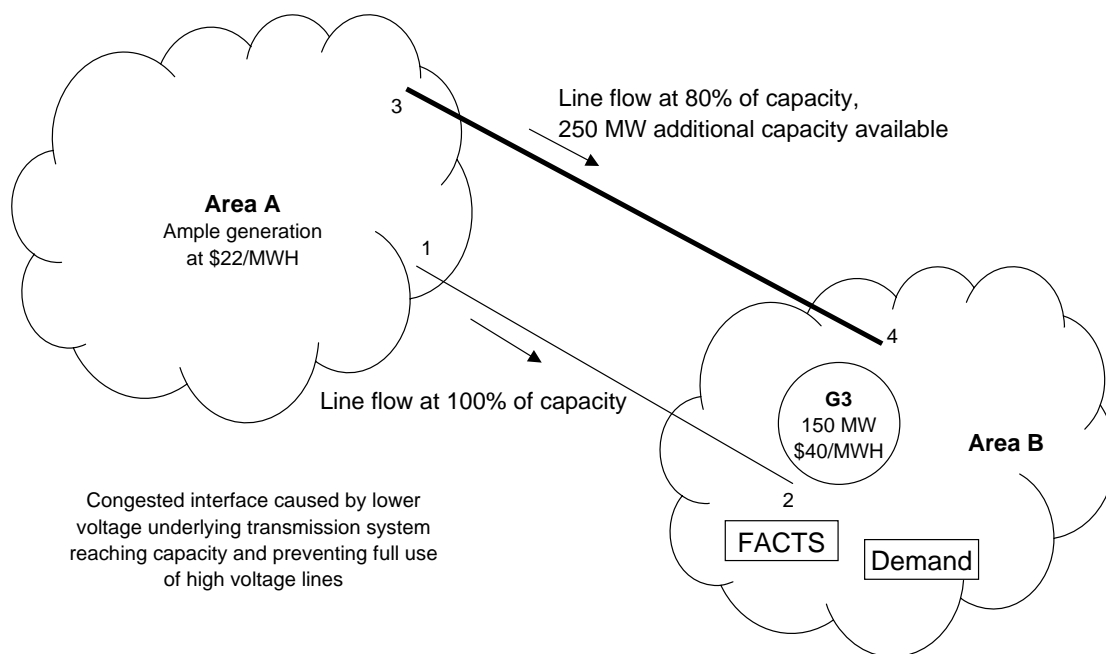

Figure 7-19. Alternatives to relieve congestion on line 1-2 and allow use of additional capacity on line 3-4.

c) Application of “Congestion” Definition to the Case of Distribution

Fundamentally, congestion is the same on the transmission system as it is on the distribution system. In both cases, congestion results when there is a desire to move more power through an element of the system than that element can accommodate. To the extent that distribution systems are often radial while transmission systems are often networked, there can be differences in how congestion is managed.

There are fewer options for dealing with congestion on radial systems that do not have generation available down stream of the congestion point than there are options for dealing with networked systems or radial systems with generation. On radial systems without generation, either the system is enhanced or the load is curtailed. The load can be curtailed through a market mechanism such as instituting geographic prices or purchasing reserves from the owner of the load. Alternatively, load curtailment can be mandated. The former option could conceivably be a long-term option, while the latter is more likely an emergency response. Networked systems or radial systems with generation can employ generation re-dispatch, load curtailment, or system enhancements to alleviate congestion.

Rather than any distinction between transmission and distribution systems themselves, it is the characteristics of the radial system versus the characteristics of the networked system that fundamentally influence the options available to alleviate congestion. For example, as shown in Figure 7-20, the transformer limits the distribution feeder to 10 MW, but the radial distribution system has 13 MW of load. (This example shows the transformer being the limiting element but it could as easily be the feeder, a bushing, or any other element.) Therefore, the feeder is congested. The congestion can be relieved in three ways:

1. Adding 3 MW of transformer capacity. This adds distribution capacity.
2. Reducing the load by 3 MW (either through a market mechanism or by direct operator control). This has no effect on distribution capacity.
3. Adding 3 MW of DG downstream of the transformer. This does not add distribution capacity.

All three of the congestion-relief mechanisms are technically viable. They each have different capital and operating costs. They each have different reliability consequences as well.

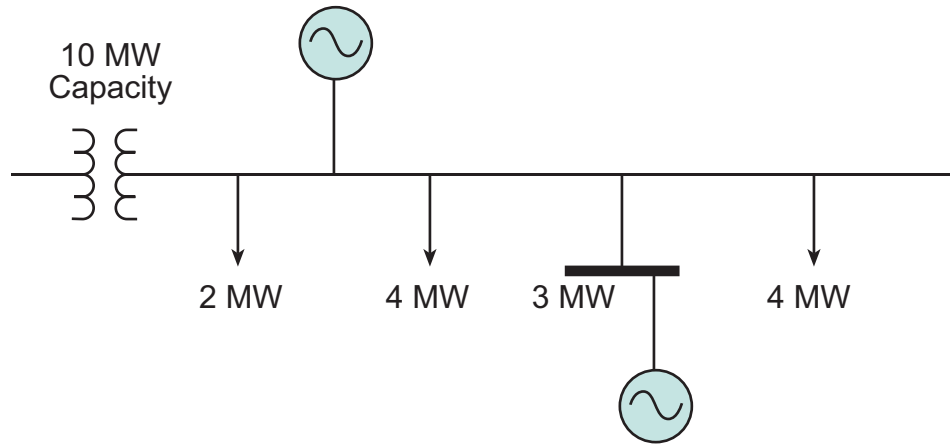

Figure 7-20. Congestion on a radial distribution line with distributed generation.

There *are* a few differences between many existing distribution feeders and most transmission lines that can limit the amount of DG that can operate at any given time. The total amount of DG (percentage penetration) that a feeder can accommodate may be limited because of the feeder protection scheme or the voltage-control capabilities. These restrictions behave like congestion in that the operation of one generator can be limited based upon the operation of another generator.

Feeder Protection Scheme: The most restrictive condition for DG dispatch occurs if the feeder protection scheme has limited ability to accommodate DG. Faults (short circuits) on distribution feeders are typically detected by sensing the high fault current flowing through the transformer to the feeder. DG connected to the feeder complicates this process. The distributed generator can contribute to the fault current and reduce the contribution coming through the transformer. If the transformer contribution is reduced enough, the feeder protection scheme may fail to detect the fault and therefore fail to take the appropriate action.

One solution is to ensure that the distributed generators' protection schemes are coordinated with the protection scheme of the feeder, perhaps requiring modifications to one or all. If the protection schemes are not coordinated, it may be necessary to limit the amount of DG connected to the feeder to a level where the existing feeder protection scheme is not degraded. For example, DG capacity might be limited to 20% of the total

feeder real power capability. In this case, the dispatch interactions among the distributed generators on the feeder are much stronger. The character of the limitation is different as well. Typical congestion limitations are concerned with the actual real and/or reactive power output of the distributed generator. An additional 20 kW of DG *output* could be accommodated by backing other distributed generators down or raising the load by 20 kW, for example. In this case, however, it is the potential fault contribution of the distributed generators that is important. Fault contribution is not tied to actual output but is a characteristic of each generator. Adding another distributed generator may require disconnecting (turning off) an existing distributed generator, not just reducing its output.

Voltage Control: The voltage-control scheme used on the feeder can also limit DG penetration. If the distributed generators are capable of actively controlling voltage and supplying or absorbing VARs as needed and if this capability is coordinated among the distributed generators and the feeder's voltage-control scheme, then the distributed generators improve the voltage control for all customers. If, however, the distributed generators do not actively control their reactive power output and instead impose reactive demands on the feeder (uncompensated induction generators, for example), then DG dispatch can be restricted by the feeder's ability to compensate for the reactive power requirements and control voltage. Dispatching an additional distributed generator would require that additional voltage control be added or that another distributed generator reduce its consumption of reactive power by reducing its real power output.

The amount of DG that can be placed on a radial line depends on the nature of various limiting conditions. Table 7-10 shows that the DG in Figure 7-19 can be limited to as little as 2 MW or as much as 23 MW.

Table 7-10. Varying amounts of distributed generation can be accommodated depending on the specific limitation of the feeder.

<i>Limiting Condition</i>	<i>Limit Calculation</i>	<i>Limit</i>
Transformer (or line) capacity	Total line load + transformer (or line) capacity	23 MW Output
Power not allowed to flow upstream through the transformer	Total line load	13 MW Output
Self generation not allowed to export	Individual load	3 MW Output
DG limited to avoid interference with the line protection scheme	20% of line capacity	2 MW Capacity

For example, consider an existing 1 MW cogenerating distributed generator located on the feeder shown in Figure 7-19. Suppose that it is desired to install a new 2 MW must-run distributed generator to relieve transformer loading. (The existing distributed generator may not be able to supply transformer relief when needed because it is a cogenerator with operations tied to other processes.) If the DG penetration on the feeder is limited to 20%, then dispatch of the new must-run distributed generator forces the existing distributed generator off, denying it access. This is an exercise of the access component of market power.

If the limitations on DG penetration due to the existing feeder protection and voltage-control schemes can be eliminated, distributed generators would face the same types of congestion limitations as any other generator on the power system. Congestion would result only when there was a desire to move more power through a transmission or distribution element than the element can handle.

d) Impact of Adding T&D versus DG Capacity on DG Dispatch

Transmission and distribution facilitate interconnection of generation and load, allowing loads to access competitive generation markets and generation to access loads. The

California ISO lists six reasons that transmission enhancements may be required.¹⁴

These apply to distribution as well:

- To interconnect generation or load (for example, build a radial line from a new generator or load to the transmission system).
- To protect or enhance system reliability (for example, replace older, less reliable equipment with newer, more reliable equipment).
- To improve system efficiency (for example, replace high-loss equipment with lower-loss equipment).
- To enhance operating flexibility (for example, add switching capability).
- To reduce or eliminate congestion (for example, add new transmission lines or increase the capacity of existing lines).
- To minimize the need for must-run contracts (for example, add transmission lines or reactive support at locations that depend on a single generator).

It is difficult to separate reliability from commerce in determining the motivation for a particular transmission project. Many real-world enhancements address multiple needs. An additional line bridging a congested interface would probably reduce congestion, increase reliability, and improve efficiency. It might also increase operating flexibility and minimize the need for must-run contracts.

Congestion can often be relieved either through modifying the existing generation dispatch, enhancing the T&D system, or causing installation and operation of new local generation. This may involve solicitation for new local generation. There are two primary distinctions between these solutions:

1. Modifying the generation dispatch involves operating costs that are incurred whenever congestion occurs, whereas enhancing the T&D system involves a T&D capital cost that is not related to the timing or duration of the congestion. Installing and operating local generation involves generator capital investment and operating

¹⁴ J. Miller 1998, *ISO Grid Coordinated Planning Process*, California Independent System Operator, Folsom, CA, January 23, www.caiso.com, accessed March 23, 2000.

costs, including, possibly, payments for must-run generation to serve local peak demand.

2. Because T&D is regulated and generation is typically market-based, the risks associated with the three solutions can be very different.

The distinction between regulated T&D and competitive generation has important implications for the risks associated with relieving congestion. Investors can earn or lose money in power markets for reasons that have nothing to do with the wisdom of their investments. Consider two investors:

- An individual studies the electricity market, notes trends in load growth and the construction of other generation facilities, and concludes that a new microturbine could lower costs to customers (itself, other local customers, or both) and make money if it were located on a congested portion of the T&D system. He invests money, builds the plant, sells plenty of power, and is doing well. Three years later, the system operator concludes that a T&D enhancement would eliminate congestion, further reduce power costs, and generally benefit the transmission grid. The new generator goes out of business, and the investor is financially ruined.
- Meanwhile, in another part of the system, another individual studies the electricity market and concludes that a T&D enhancement could lower the cost to customers and reduce congestion. He takes the idea to the system operator, which concurs and obtains regulatory approval. He builds and operates the enhancement under contract to the system operator. Three years later, improved distributed generators are installed throughout the region, and the T&D enhancement is completely unnecessary. Because the cost of the enhancement is in the rate base, customers continue to pay the investor for the enhancement, and the modest regulated income is protected.

Generation investors have to contend with the risk that newer generation or T&D investments will render their investments obsolete. The same is generally not true for investments in T&D, which are protected by regulation. Regulators and regional transmission organizations will have to be careful to ensure that the fear of ending up

like the generation investor above does not discourage investors from entering the market for new generation.

Had the T&D investment in the above example been a commercial, competitive investment rather than a regulated investment, the risk situation would be completely different. One or more loads in the congested area could decide that investing in a T&D enhancement would give access to lower cost generation and be a good investment. Similarly, one or more remote generators could decide that investing in a T&D enhancement would give access to additional loads and be a good investment. Control of the enhancement would have to be given to the system operator, but the investors could retain rights to *income* derived from the enhancement (through transmission congestion contracts or other mechanisms). In this situation, the T&D investors bear the risk that the investment will be worthwhile. If it is not, they receive no benefit from reduced power prices or increased sales.

e) Technical Feasibility of DG Providing Ancillary Services

Providing regulation, spinning reserves, non-spinning reserves, and replacement reserves fundamentally involves control of real power injections or withdrawals from the power system to help maintain the real-time balance between aggregated generation and load while respecting T&D constraints. If appropriate communications and controls can be provided, distributed generators should be excellent resources for providing ancillary services. It may be necessary to reexamine the NERC, WSCC, and CAISO requirements for supply of these services to ensure that the requirements are technology-neutral and results-oriented.

Dispatchable distributed generators (microturbines and engine-driven generators, for example) tend to respond rapidly. Aggregated together, their combined ramp rates can be high. Their small size and independence makes them desirable from a reliability point of view. If common-mode failures can be avoided (communications links, common fuel supply, and so on), the response from a fleet of distributed generators will likely be much more predictable than the response from a large central generator that will, on occasion, completely fail to respond. Clearly, aggregation, communications, and control must be examined carefully.

Distributed generators will likely *want* to sell some or all of the market-based ancillary services. While the average price for the services may not be attractive, the hourly prices in the afternoon and evening may be. Providing distributed generators (and loads) access to these markets helps them by giving them another source of income, helps the overall power system by increasing the supply of reliability services, and helps all customers by reducing the cost of reliability through increased market participation on the supply side.

Most distributed generators will likely not participate in selling voltage control and reactive support for the bulk power system. Unlike regulation and the three reserve services, voltage control is very location-specific. Furthermore, support has to be provided at the transmission or sub-transmission voltage level. Finally, the quantities of reactive power required at each location are typically more than a distributed generator can provide. Those distributed generators that are appropriately located, connected at transmission or sub-transmission voltage, and have sufficient reactive power capability should be allowed to compete for contracts with the system operator to supply this service, however.

Distributed generators that cannot supply voltage control (support) to the bulk power system often will be able to supply reactive power that helps control (support) the voltage on the distribution system. This can have real value by improving the quality of power supplied to other local customers. It can also lower the capital and operating cost of the distribution system by reducing or eliminating the need for other voltage control equipment like switched capacitors or load-tap-changing transformers.

Black start presents a similar differentiation. Distributed generators that can provide black start capability to the bulk power system should be allowed to do so. Most distributed generators, however, will not have sufficient real or reactive power capability to be useful in restoring the bulk power system. They may be very useful in selling emergency power to other local customers, however. This service could be independent of the distribution system if the distributed generator is co-located with a particular load to which it is supplying emergency power. The approval and cooperation

of the distribution system operator is required for the distributed generator to provide this service to other local loads.

Non-generation resources can supply many of the ancillary services as well.

Controllable load is likely the largest untapped ancillary resource currently available. Though it is unlikely that controllable load will provide regulation (it may be able to reduce its own regulation consumption), it is an ideal source of spinning reserve, non-spinning reserve, and replacement reserve. As with DG, it is important to make sure ancillary service specifications are technology-neutral and results-oriented. For example, load is generally excluded from providing spinning reserve based on a service definition that required the resource to be a “spinning” generator. This specification could instead require a specific real-power response within a specified amount of time. It could also require that the resource provide specific responses to changes in system frequency (amount of real power within a defined amount of time for a specific frequency deviation) rather than simply requiring that the generator have an operating governor.

Voltage control and reactive power provision is a service that can come from T&D resources as well as from generation. Capacitors and reactors (inductors) provide fixed amounts of reactive power. They can be switched to provide some control. Non-generation resources such as synchronous condensers and static VAR compensators can provide dynamic response.

7.D.10 Ancillary Services in a Restructured EPS

Ancillary service markets were redefined several times in 1999 making strict comparisons and summaries difficult. Still, the system required, the ISO purchased, and resources delivered four ancillary services through markets every hour of the year: regulation, spinning reserve, non-spinning reserve, and replacement reserve. Table 7-11 presents 1999 annual average required quantities and market prices for these four services.

Table 7-11. 1999 Average ancillary service quantities and prices.

<i>Ancillary Service</i>	<i>MW</i>	<i>\$/MW-Hr</i>
Regulation	1637	\$19.96
Spinning Reserve	766	\$6.89
Non-spinning reserve	676	\$4.25
Replacement reserve	281	\$7.64

If average prices and quantities were representative, there would be no need to run hourly markets for ancillary services or energy. Because prices and required quantities fluctuate dramatically, hourly markets are required. The average hourly weekday variation in ancillary service requirements for September 1999 is shown in Figure 7-21, while the hourly prices are shown in Figure 7-22.

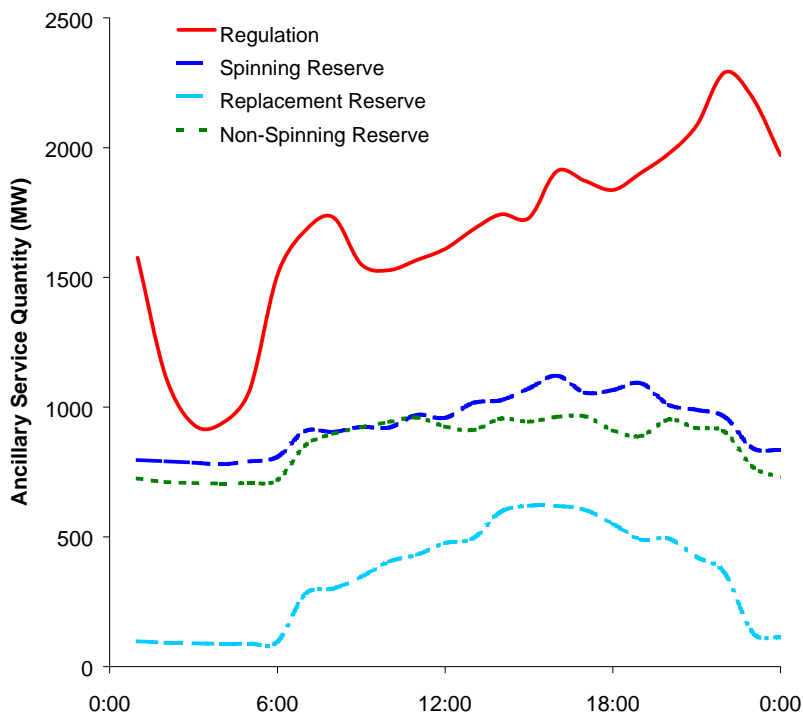

Figure 7-21. Average hourly ancillary service quantities for September 1999 weekdays.

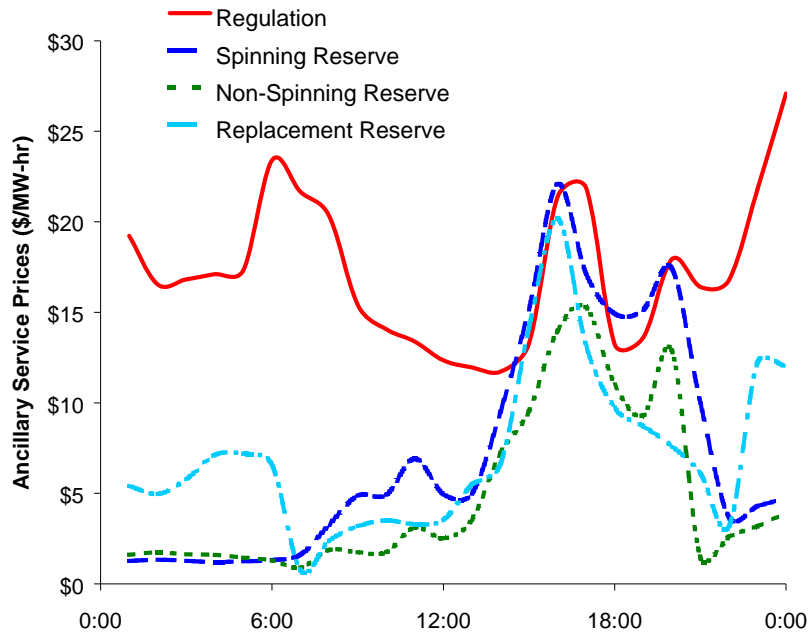

Figure 7-22. Average hourly ancillary prices for September 1999 weekdays.

Distributed generators will likely want to sell some or all of these market based ancillary services. While the average price for the reserve services (for example) may not be attractive the hourly prices in the afternoon and evening may be. Providing distributed generators (and loads) access to these markets helps them by giving them another source of income, helps the overall power system by increasing the supply of reliability services, and helps all customers by reducing the cost of reliability through increased market participation on the supply side.

Glossary

1998 Assembly Bill No. 1755. A California state bill that updated the State Public Utility Code, which allows “net metering” for wind and solar electric systems rated at 10 kW or less.

Adequacy. Adequacy refers to the ability of the transmission and distribution system to handle the load and generation, even during known and expected outages. The transmission and distribution system must have enough capacity so that competitive generation markets can function.

Ampacity. The current-carrying capacity of a conductor measured in amperes.

Ancillary Energy Service. A service that is necessary to support the transmission of reliable electric power from seller to purchaser. These services include regulation, which balances generation and load demand under normal operating conditions. Other services include spinning reserve, non-spinning reserve, and replacement reserve, which facilitate this balancing in the aftermath of system disturbances that lead to abnormal operating conditions.

Auxiliary Energy Loss. The portion of the generated energy that is used in the generation process is called *auxiliary energy losses* or *plant losses*. These losses can be calculated by subtracting the net plant output from the gross energy generation.

Available Energy

Average Service Availability Index (ASAI). The average service availability index represents the fraction of time (often in percentage) that a customer has power provided during one year or the defined reporting period.

Black Start. An ancillary service provided by generators. The independent system operator determines the system's black start requirements needed to ensure that the system can be restored to service expeditiously if it should ever fail completely. Each black start unit must be capable of starting, without external assistance, within ten minutes. It must also be capable of supplying the reactive power requirements, controlling the voltage of the energized transmission system, and operating for a minimum of 12 hours.

Bulk Power. An interconnected system for the movement or transfer of electric energy in bulk on transmission levels.

Central-Station Generator. Large electric generators used in centrally located power generation plants. Central-station generators usually range from 10 MW to 1300 MW.

Combustion Turbine. A new, distributed-generation technology, combustion turbines are sized in the 10-to-100-megawatt range and they have transformed from expensive peaking units to base-load-capable generators with efficiencies above 55 percent when operated as combined-cycle plants.

Congestion. Congestion occurs when there is a desire or need to move more power through a portion of the transmission and distribution system than the system can support.

Control Area. The area of the electric grid controlled by the independent system operator.

Current Distortion. Current distortion occurs when there is a nonlinear relationship between input and output frequency, there is nonuniform transmission at different frequencies, or there is a phase shift not proportional to frequency.

Current Quality. The quality of current— measured by the output current regulation and waveshape—required for interconnection with the public power supply or for serving local load equipment.

Customer Average Interruption Duration Index (CAIDI). CAIDI represents the average time required to restore service to the average customer per sustained interruption.

Deregulation. On October 24th, 1992, Congress passed Public Law 102-486, the Energy Policy Act (EPAct), which deregulates the electric utility industry to promote competition among suppliers of energy products and services.

DG. (See Distributed Generation).

Dispatch. The transmission of electric power to customers.

Dispatchability. Dispatchability is the ability to switch between the non-operating and the operating states (and visa-versa) upon command. Measurement factors include minimum on-time, minimum off-time and minimum startup time.

Distributed Generation. Today, most electricity is generated from large, centralized electric generators ranging in size from 10 MW to 1300 MW. However, in the distributed generation model, electricity is produced from numerous small generators—usually a few tens of KW to a few hundred KW— located very near the loads themselves. Distributed generation can supply part of the local load, reducing the loading on the transmission and distribution system. This can reduce congestion or eliminate the need for T&D enhancements. Distributed generation can also supply energy and/or ancillary services back to the power system via the independent system operator.

Distributed Resources. (See Distributed Generation).

Distribution Station. (See Substation).

Duty Cycle. Most end-use consumption is not in operation all the time or goes through different loading cycles. The variation in load demand during a complete cycle of operation is known as duty cycle.

Economic Dispatch. The distribution of total generation requirements among alternative sources for optimum system economy with due consideration of both incremental generating costs and incremental transmission losses.

Efficiency. Efficiency is the ratio of the electric energy generated to the primary energy supplied. The primary losses usually occur in the thermal cycle for conversion from heat to mechanical energy. Additional losses occur in the electric generator for conversion from mechanical to electric energy.

Energy Capacity. Energy capacity is the ability to deliver power over a length of time. This characteristic is measured in MWH or KWH. The ratio of the energy capability (over a year, for example) to power capacity is the capacity factor.

Energy Consumption. Energy consumption is the amount of energy consumed over the billing period. This is measured in MWH or KWH.

Flicker. Flicker, which is most noticeable in lighting systems and computer monitors, results directly from the interaction of transmission and distribution with time varying loads. Arc furnaces, welders, and motor starting have been primary causes of flicker in the T&D system. Usually flicker is measured using the GE flicker curve, which defines the objectionable range of irritation based on the frequency and magnitude of voltage variation.

Fuel Cell. A fuel cell is a device that generates electric power from a reverse-electrolysis process where hydrogen gas is reformed to produce electricity and water.

Harmonic Distortion. Harmonic distortion is distortion in current or voltage waveshapes caused by switching in non-linear loads.

Impedance. The electrical nature of the load device may be primarily resistive, capacitive or inductive. These characteristics can be directly measured in ohms at 60 Hz, or in frequency-independent Ohms, Farads and Henries. Electronic equipment has the special characteristic of a non-linear or varying impedance. Practices for measuring the impedance of non-linear electronic equipment have not been established except with respect to harmonic distortion measures.

Induction Generator. A generator that will generate AC current into the electric system as long as the mechanical speed of the turbine exceeds the synchronous frequency of the induction machine and electric system.

Inrush Current. Inrush current, or starter current, usually results from the start up of induction motors, requiring from 3 to 8 times the normal current. Inrush is measured as a multiplier or percent of full rated current.

Interruption. The loss of service to one or more customers. Note: It is the result of one or more component outages, depending on system configuration. See outage.

Interruption, duration. The period (measured in seconds, or minutes, or hours, or days) from the initiation of an interruption to a customer or other facility until service has been restored to that customer or facility. An interruption may require step-restoration tracking to provide reliable index calculation. It may be desirable to record the duration of each interruption.

Interruption, forced. An interruption that results from conditions directly associated with a component requiring that it be taken out of service immediately, either automatically or as soon as switching operations can be performed, or an interruption caused by improper operation of equipment or human error. Note: This definition derives from transmission and distribution applications and does not necessarily apply to generation interruptions.

Interruption, momentary. Single operation of an interrupting device, which results in a voltage zero. For example, two breaker or recloser operations equals two momentary interruptions.

Interruption, momentary event. An interruption of duration limited to the period required to restore service by an interrupting device. Note: Such switching operations must be completed in a specified time not to exceed 5 minutes. This definition includes all reclosing operations, which occur within five minutes of the first interruption. For example, if a recloser or breaker operates two, three, or four times and then holds, the event shall be considered one momentary interruption event.

Interruption, scheduled (electric power systems). A loss of electric power that results when a component is deliberately taken out of service at a selected time, usually for the purposes of construction, preventative maintenance, or repair. Notes: (1) This derives from transmission and distribution applications and does not apply to generation interruptions. (2) The key test to

determine if an interruption should be classified as a forced or scheduled interruption is as follows. If it is possible to defer the interruption when such deferment is desirable, the interruption is a scheduled interruption; otherwise, the interruption is a forced interruption. Deferring an interruption may be desirable, for example, to prevent overload of facilities or interruption of service to customers.

Interruption, sustained. Any interruption not classified as a momentary event. Any interruption longer than 5 minutes.

Laterals. Laterals are short line segments that branch off the primary feeder and make the final primary voltage connection from the substation to the customer.

Line-Commutated Inverter. Line-commutated inverters use a bridge configuration to invert DC power. These devices rely on the power system voltage to force output current through zero and to turn off the switch, hence the term “line-commutated.”

Load Diversity. (See Duty Cycle).

Loop System. A distribution loop system provides two paths between the power sources (substation and service transformers) and every customer. Equipment is sized and each loop is designed so that service can be maintained regardless of where an open point might be on the loop.

Network System. A system whereby there is more than one electrical path between any two points in the system. Networks are laid out like this for reasons of reliability and optimum power flow—if any one element of the network fails, there is an alternative path, and power is not interrupted.

Peak Demand. Peak demand, measured in MW or KW, is the maximum 15 or 30 minute energy consumption timeframe. It is often measured at the time when the power system sets its peak demand (coincident peak).

Photovoltaics. A system that converts sunlight directly into electric energy and processes it into a form suitable for use by the intended load. The system will include an array subsystem and may also include the following major subsystems: power conditioning, storage, thermal, and system monitor and control. A photovoltaic (PV) system-utility interface may also be included.

Plant Loss. (See Auxiliary Energy Loss).

Plt. The value used to measure long-term flicker.

Power Capacity. The ability to deliver real power to the power system. Power capacity is measured in MW or KW.

Power Factor. Power factor is the ratio of the real power consumed to the apparent power. This is a measure of the reactive power requirement of the load.

Power System Stabilizers. An element or group of elements that provide an additional input to the regulator to improve power system performance. Note: A number of different quantities may be used as input to the power system stabilizer, such as shaft speed, frequency, synchronous machine electrical power, etc.

Primary Feeder. Any part of the distribution-level voltage lines—three-phase, two-phase, or single-phase—that is switch-capable is considered part of the primary feeder.

Pst. The value used to measure short-term flicker.

Public Utilities Regulatory Policy Act of 1978 (PURPA). PURPA enabled independent generators to sell electricity to regulated utilities.

PURPA. (See Public Utilities Regulatory Policy Act of 1978).

PV System. (See Photovoltaics).

Radial System. The radial system uses only one path between each customer and the substation. Regulators and capacitors can be sized, located, and set using relatively simple procedures because the direction of power flow is known.

Ramp Rate. The ability to change power output, measured in MW/min. This is also often taken as a measure of controllability because currently there is no good controllability metric.

Rational Buyer. The “rational buyer” was instituted in August of 1999, allowing the independent system operator to substitute a higher-quality ancillary service (like regulation) for a lower quality ancillary service (like non-spinning reserve) if the substitution was cost effective.

Reactive Power. Reactive power is the total reactive capability (MVAR) that a generator can support at full output.

Recloser. The automatic closing of a circuit-interrupting device following automatic tripping. Reclosing may be programmed for any combination of instantaneous, time-delay, single-shot, multiple-shot, synchronism-check, dead-line-live-bus, or dead-bus-live-line operation.

Regional Transmission Organization (RTO). FERC's Order 2000, issued in December of 1999, dealt with RTO, reaffirming FERC's commitment to restructuring the electric utility industry throughout the U.S.

Reliability. A measure of the availability of power to the consumers. The principle determinants of reliability of a power system are factors that relate to frequency and duration of service interruptions.

Reliability Index Survey. Two recent surveys on distribution reliability were conducted to determine index usage. In 1990, 100 US utilities were surveyed, 49 of which responded. In 1995, 209 utilities were surveyed, 64 of which responded.

Renewable Energy Resources. California continues to promote new generation from renewable energy resources. The 1998 Assembly Bill No 1755 updated the State Public Utility Code that allows "net metering" for wind and solar electric systems rated at 10 kW or less. The CEC is currently in the process of developing a screening process to identify distributed generators that require minimal review and studies by utility distribution companies and minimal additional interconnection requirements.

Replacement Reserve. Usually generators, loads, or resources from outside the independent system operator's area, replacement reserves must be used so the electrical system is prepared for a subsequent unexpected outage. Replacement reserves must be capable of responding within one hour and sustaining that response for an additional two hours.

RTO. (See Regional Transmission Organization).

SCR. (See Short-Circuit Ratio).

Sectionalizer. Automatic sectionalizers work by detecting the presence of a fault current downstream of their location. When such current is detected, they wait for a circuit breaker upstream of their location to de-energize the line. Once this occurs, the sectionalizer contacts open. When the upstream breaker recloses, the faulted section of line will have been removed from the circuit.

Self-Commutated Inverter. A self-commutated inverter is able to invert DC current by commutating switches on and off in order to reverse current in both directions. With on/off switching control, a self-commutating inverter can control frequency. Many self-commutated designs are also able to regulate and shape the output current using switching techniques such as pulse-width-modulation. In this regard, the self-commutated inverters act like a synchronous generator and are able to supply real and reactive power, suitable for powering isolated or interconnected loads.

Self-Provision. Self-provision of ancillary services is an option that is sometimes exercised by power producers. Beginning in June, 1999, a scheduling coordinator can provide the independent system operator with ancillary service resources instead of paying the ISO for ancillary services. This same option may be applicable at the distribution level.

Short-Circuit Ratio (SCR). An SCR is the short circuit power divided by the average or maximum demand power of the load (or distributed generator) being evaluated. This parameter is also referred to as “stiffness ratio.” A stiffness ratio of greater than 100 may allow a DG to be connected with fewer interconnection requirements than a system with a ratio of 20.

Solar Electric Systems. (See Photovoltaics)

Spinning Reserve. The reserve energy available from the energy provider. Spinning reserve must be frequency responsive, and provided by generation.

State Public Utility Code. (See 1998 Assembly Bill No. 1755).

Stiffness Ratio. (See Short-Circuit Ratio)

Substation. A transforming station where the transmission is linked to the distribution system.

Sub-Transmission. The sub-transmission lines in a system take power from the transmission switching stations or generation plants and deliver it to substations along their routes. A typical sub-transmission line may feed power to three or more substations.

Synchronous Generator. The generator used in nearly all electric generating plants. In a synchronous generator, an electromagnet or a permanent magnet on the rotor produces the magnetic field. As a consequence, the frequency of the AC electric power produced (60-Hz, for

example) is exactly related to the rotational speed and number of poles of the generator rotor (1800 RPM, for example). Similarly, the magnitude of the voltage produced (and the reactive power delivered to the power system or consumed by the generator) is directly related to the strength of the magnetic field in the rotor. A wound-rotor synchronous generator with rotor field current control can regulate its own output voltage as well as the ratio of real to reactive power

System Average Interruption Duration Index (SAIDI). This index is commonly referred to as Customer Minutes of Interruption or Customer Hours, and is designed to provide information about the average time that customers are interrupted.

System Control. The requirement to maintain the real-time balance between generation and load, coupled with the inability to independently control flows on individual transmission and distribution lines, results in the need for a system control function.

T&D. (See Transmission and Distribution).

Tap-Changing Mechanism. A selector switch device used to change transformer taps with the transformer de-energized.

THD. (See Total Harmonic Distortion).

Total Harmonic Distortion. Nonlinear distortion of a system or transducer characterized by the appearance in the output of harmonics other than the fundamental component when the input wave is sinusoidal.

Transmission System. The transmission system is a network of three-phase lines operating at voltages generally between 115 kV and 765 kV. Capacity of each line is between 50 MVA and 2,000 MVA.

Transmission and Distribution. The system that carries electric power to customers. It must be dispersed throughout the utility service territory in rough proportions to customer locations and demand. The system must reach every end user with an electrical path of sufficient capacity to satisfy that end user's demand for electrical power.

Voltage Distortion. Voltage distortion occurs when there is a nonlinear relationship between input and output frequency, there is nonuniform transmission at different frequencies, or there is a phase shift not proportional to frequency.

Voltage Level. Transmission and distribution lines are characterized by the voltage level at which they normally operate. Voltage is an important characteristic of T&D. It is possible to

move more power through a smaller right-of-way with lower losses and at lower capital cost if the voltage is raised.

Voltage Quality. Voltage quality needs to be suitable for interconnection with the public power supply or for serving local load equipment. When the generator is operated as a voltage source, voltage quality is measured by the output voltage regulation, waveshape, and frequency.

Voltage Support. The ability to produce reactive power and control the local power system voltage is a valuable characteristic. This is measured in terms of the total reactive capability (MVAR) or in terms of the power factor that the generator can support at full output.

Waveform Distortion. (See Harmonic Distortion).

Appendix 7.A Distributed Generation versus Load

Electric power is the original plug-and-play industry: The electric power customer has traditionally been responsible for ensuring that appliances connected to the power system are suitable and safe. This is unlike the telephone company, which for decades controlled (and generally supplied) all devices the customer was permitted to connect to the phone system. The devices themselves (appliances, lamps, and so on) require Underwriters Laboratories (UL) or other certification, which is the responsibility of their manufacturers. But it is the energy user's responsibility to ensure that overall facility wiring—and specifically wiring for major loads—meets applicable codes. Local government inspectors verify that the energy user is meeting this responsibility. Today, for both the phone and the electric company, the utility's responsibility ends at the interface between user and utility. Thus, it is instructive to examine the interconnection requirements for loads to see what can be learned about small-scale DG.

Separate standards apply for utilities and energy users. Standards for safe operation and maintenance of equipment in buildings are established by states and are generally based on the National Electric Code. Standards for safe operation and maintenance on the utility system are established by the utility and are generally based on IEEE and NERC standards. Each party is generally exempt from following the standards that apply to the other party. It is not surprising that confusion results when the utility imposes requirements in an environment that it is normally excluded from.

When an energy user wants to connect a load to the power system, utilities do not impose onerous information, process, or technical interconnection requirements. They do not demand the right to test every load before it is placed on the system. Generally little more than the expected total peak load is discussed when the customer's building first connects to the power system. Only when the load becomes quite large do utility engineers show any interest in specifics. Restrictions on the harmonics a load can inject into the power system or the minimum acceptable power factor are stated requirements that the customer lives with.

Similarly, the utility agrees to provide the customer with power within a specific voltage and frequency range. To a greater or lesser extent, the supplied power must meet limitations on transients, harmonics, dropouts, and flicker. These limitations are specified in contracts, standards, or regulations.

QUALIFICATIONS AND PREPARED TESTIMONY
OF
Thomas Key

Q.1 Please state your name and business address.

A.1 My name is Thomas Key. My business address is 10521 Research Drive, Knoxville, Tennessee, 37932.

Q.2 By whom are you employed and in what capacity?

A.2 I am employed by the EPRI-PEAC Corporation, as VP of Technology.

Q.3 Briefly describe your pertinent educational and professional experience.

A.3 I am a graduate Electrical Engineer with a Master's degree specializing in the area of Electric Power Systems. I have worked in the field of engineering for 30 years, including 10 years in the US Navy Civil Engineer Corps, 10 years at the Sandia National Laboratory and 10 years where I am currently employed, at EPRI PEAC. EPRI PEAC is a wholly-owned subsidiary of EPRI (a research arm of the electric utility industry). My experience pertinent to this testimony is primarily in the area of electrical compatibility issues, functions and interactions between components of the electric power system. Specific experience has been in power system component research and testing, at Sandia to interconnect solar electric generators, and at PEAC to create a compatible interface of end use loads, with the electric power supply system.

I have more than 20 years contributing to IEEE standards for compatible interface of end-use equipment and distributed power systems. I have managed many R&D projects, including the design and testing of photovoltaic electrical power system, development of grid-connected power inverters for conditioning and control of distributed power sources, creation of recommended practices for the design of photovoltaic power system electrical wiring and protection, development of criteria for a utility grid-compatible interface, characterization of high-performance dc/ac inverters, monitoring of power and effects of power disturbances in sensitive electronic equipment, and development of design criteria and recommended practices for cost-effective application of power-enhancement equipment. At EPRI-PEAC I conceived and

designed the power laboratory and developed criteria to address the compatibility of new electronics technologies. I have published more than 50 professional papers, monographs, and technical articles. This work has been recognized recently by the John Mungenast International Power Quality Award for distinguished power quality research. I also received the 1996 Outstanding Engineer Award, Region 3, the Institute of Electrical and Electronics Engineers.

Q.4 What is the purpose of your testimony?

A.4 The purpose of my testimony is to provide a technical evaluation of operational and ownership question related to distributed generation in California, In my testimony I describe fundamentals regarding the technical structure and functions of electric power system components and to provide analysis of how functional unbundling and distributed generation will address policy objects established for the electric services industry in California by the State Legislature.

Q.5 What is the scope of your responsibility in this proceeding?

A.5 I am responsible for the analyses and recommendations in Chapter 7, Sections B and C, Background and Fundamentals of the Electric Power System.

Q.6 Does that conclude your testimony?

A.6 Yes, at this time.

QUALIFICATIONS AND PREPARED TESTIMONY

OF

Brendan Kirby

Q.1 Please state your name and business address.

A.1 My name is Brendan J. Kirby. My business address is 2307 Laurel Lake Rd, Knoxville, TN. 37932

Q.2 By whom are you employed and in what capacity?

A.2 I am a private consultant. I am also employed by the Oak Ridge National Laboratory, operated by UT-Battelle, as the Director of the Power Systems Research Program. My testimony here is given as a private consultant with EPRI PEAC Corporation and does not represent my employment with Oak Ridge National Laboratory or my employer.

Q.3 Briefly describe your pertinent educational and professional experience.

A.3 I graduated from Lehigh University, Bethlehem Pennsylvania with the degree of Bachelor of Science in Electrical Engineering in 1975 and from Carnegie-Mellon University, Pittsburgh Pennsylvania with the degree of Masters of Science in Electrical Engineering, Power Option in 1977. I started my professional career with Long Island Lighting Company in 1975 and moved to the Department Of Energy's facilities in Oak Ridge Tennessee in 1977, employed by the operating contractor working on various power system issues. Since 1994 I have been with the Oak Ridge National Laboratory portion of those facilities, at first as a Senior Researcher and now as the Director of the Power System Research Program. My research activities include electric industry restructuring, unbundling of ancillary services, distributed resources, demand side response, energy storage, renewable resources, and advanced analysis techniques. I am also a member of the NERC Interconnected Operations Services Working Group, IEEE SCC 21 Distributed Generation Interconnection Standard working group, served as staff to the Department of Energy's Task Force on Electric System Reliability. I have authored or co-authored 47 published reports, articles, and technical papers on electric industry restructuring, ancillary services, demand side market response, reliability, and storage. My private consulting practice includes utilities, power marketers, EPRI, EEI, regulators, and others on electric utility restructuring and other issues. I have testified as an expert

witness in FERC litigation. I am a licensed Professional Engineer registered in the state of Tennessee.

Q.4 What is the purpose of your testimony?

A.4 The purpose of my testimony is to present my analysis of the technical issues pertaining to distributed generation and the distribution system in which it is to be situated and recommendations regarding the functional unbundling of distribution services needed to accommodate distributed generation.

Q.5 What is the scope of your responsibility in this proceeding?

A.5 I am responsible for my analyses and recommendations in Chapter xx, Technical Evaluation of Operational and Ownership Issues of Distributed Generation in California, Section A, Summary and Key Findings, Section D, Analysis of Distributed Generation Impacts.

Q.6 Does that conclude your testimony?

A.6 Yes, at this time.